

### GENERAL FEATURES

“Ego” is a cutting-edge range of electronic circulators that fully comply with European Directive ErP 2009/125/CE.

All Ego circulators feature the **ECM technology (electronically commuted motor with rotor equipped with permanent magnets)**, that enables automatic and continuous regulation of the pump (flow rate/head) depending on the actual requirements of the system, ensuring important energy savings.

### APPLICATIONS

Ego circulators are specifically designed for heating systems and circulation of liquids in air-conditioning systems.

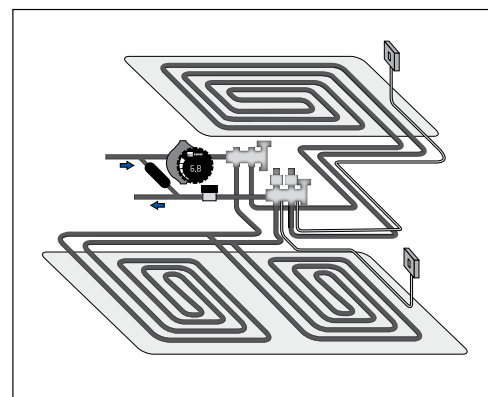
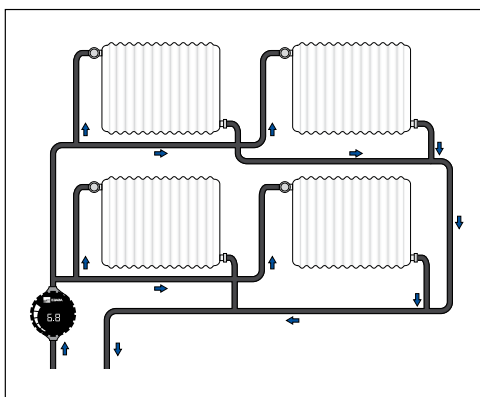
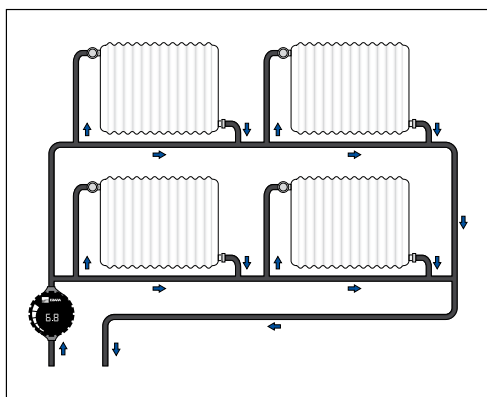

### Heating systems

The pumps are suitable for single-pipe systems, two-pipe systems, underfloor heating systems and mixing loops of great installations. All Ego circulators automatically and autonomously control the differential pressure, adjusting pump performance in accordance with heating requirements.

### Air-conditioning systems

Please refer to the minimum allowed temperatures of every product range to see how to use the Ego pumps. Some models are suitable for circulation at temperatures below 0°C (they are, therefore, particularly recommended for air-conditioning and/or refrigeration systems).

### CONSTRUCTION

All Ego pumps are wet-rotor type; therefore, the pump and the motor make up a single unit with no mechanical seal; rotor bearings are lubricated directly by the pumped liquid. One of the most important features of Ego circulators is **the rotor can, made of a single part in AISI 316 stainless steel without welding points**: this solution, present on all Ego models, ensures hermetic, stable and reliable separation of the stator from the parts that come into contact with the liquid.

Other design features common to all Ego models are the following:

- Rotor in material resistant to corrosion
- Pump body in cataphoresis treated cast iron
- Low-friction bearings with consequent low noise emissions and reduced power consumption

For details on materials used please refer to the technical data sheets of every model.

## HIGH PERFORMANCE ELECTRONIC CIRCULATORS

in cast iron with cataphoresis coating

### PUMPED LIQUIDS

Ego circulators are suitable for the circulation of:

- clean, non-aggressive and non-explosive, free of solid particles or fibres (in compliance with VDI 2035)
- water/glycol mixtures

### Liquid viscosity

During pump selection phase, one of the most important criteria is liquid viscosity that affects (reduces) the maximum performance of the circulator. In particular, **when using water/glycol mixtures with concentrations higher than 20%, the final viscosity should be verified carefully**, as it represents the criteria for selecting the most suitable circulator (contact our technical support centre for further information).

Hydraulic performance and all main technical data given in this catalogue refer to liquids with viscosity of 1mm<sup>2</sup>/s at 18°C.

### Temperature del liquido e ambiente

Gamma temperature fluido ammesse:

- |   |                  |
|---|------------------|
| • Mod. Ego small (mod. Ego -/40, -/60, -/80):     | da +5 a +95 °C   |
| • Mod. Ego medium (mod. Ego easy -60, -80, -100): | da +2 a +110 °C  |
| • Mod. Ego large (mod. Ego slim, Ego, Ego H):     | da -10 a +110 °C |
| • Mod. Ego B for sanitary plants:                 | da +5 a +65°C    |

Room temperature allowed ranges from 0 to 40°C, with relative air humidity below 95%. In the event of use with fluids at low temperature, room temperature should always be lower than liquid temperature to prevent condensate from building up on stator casing.

### Input pressure

In order to avoid noise, cavitation phenomena and damaging the bearing, it is essential to ensure a minimum pressure at suction inlet at all times (check the manuals of every model to see the minimum pressure values in relation to fluid temperature).

### Maximum operating pressure

The maximum operating pressure for all **Ego models is 1 MPa (10 bar) – PN10.**

### ASSEMBLY POSITION

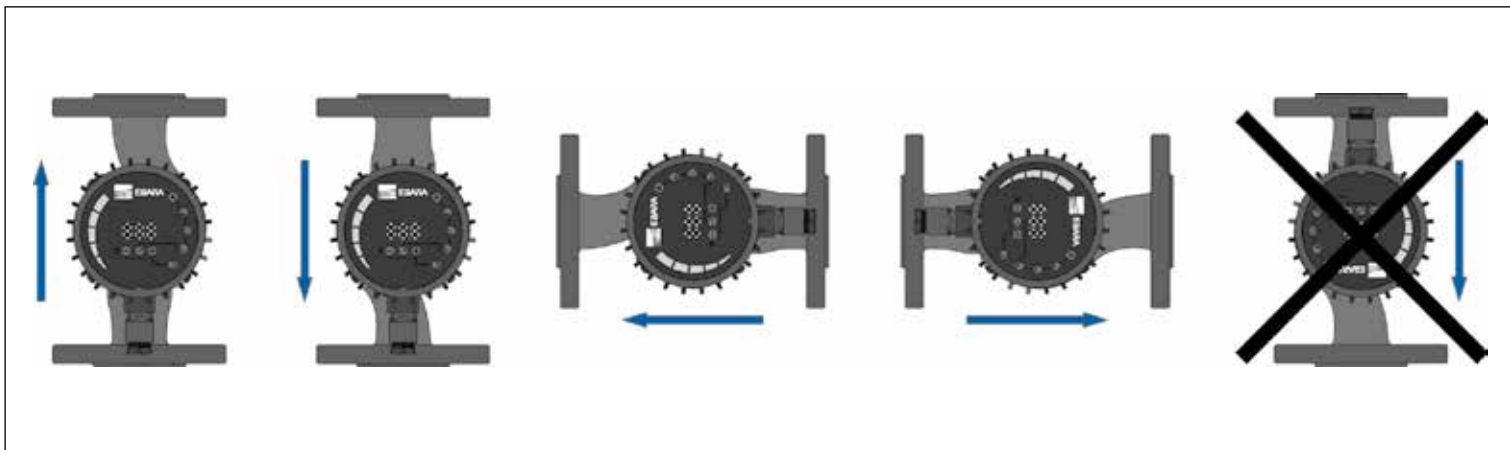

All Ego circulators should be installed with the **motor shaft in full horizontal position**, as shown in the figure above (example valid for all models). **The power cord should never be positioned upwards** (it may facilitate water inflow into the terminal box): in these cases, you should rotate the electronic unit or pump's body (please refer to the manual).



## GAMMA Ego

### HIGH PERFORMANCE ELECTRONIC CIRCULATORS

in cast iron with cataphoresis coating

#### ELECTRICAL FEATURES AND REGULATION

All Ego models are equipped with synchronous motor with rotor with permanent magnets and built-in frequency converter (ECM technology); **the electronic board measures the current consumption and calculates the instant pressure and flow rate to ensure continuous adjustment of hydraulic performance.** If the requested flow rate drops (usually when system valves close), the frequency converter automatically reduces the number of revolutions and, therefore, the power consumption. Variations may reach to 1/5 of maximum pump capacity.

Therefore, this technology ensures:

- **Continuous adjustment of performance in accordance with the actual requirements of the system**
- **High efficiency**
- **Great starting torque (automatic release even after long periods of inactivity)**
- **Complete motor protection**

#### Supplied voltage

The supplied voltage for all Ego models is **1-230V - 50/60 Hz**

#### Control modes

The built-in electronic board enables, depending on the model, various control modes such as:

- **Automatic regulation**
- **$\Delta P-v$  Proportional pressure**
- **$\Delta P-c$  Constant pressure**
- **Constant speed**
- **Current limit control**
- **Power limit control**

(Please refer to the data sheets of every model to check the available control modes).

## HIGH PERFORMANCE ELECTRONIC CIRCULATORS

in cast iron with cataphoresis coating

### CONNECTIONS AND REMOTE CONTROL

Depending on the models, the following additional connections are available:

#### a) Analog external regulation (contact 0-10V)

The external contact 0-10V can be used in various modes:

- in "constant speed" regulation mode, the external contact 0-10V enables switching from a constant curve to another, according to the value of the input signal.
- in "proportional pressure" regulation mode, the external contact 0-10V enables switching from a variable curve to another, according to the value of the input signal.

With signals below 1V, the circulator enters stand-by mode.

#### b) Control from PC (Ethernet connection)

Some Ego models can be fully programmed and controlled remotely via the PC, using an Ethernet connection. The connections modes are 2:

- **Direct connection** "circulator – PC" (with CROSS-OVER type cable) - **Fig. 1**
- **Network connection** via router (with PATCH cable) - **Fig. 2**



Once you have completed the Ethernet connection, you can access the circulator using any internet browser (Chrome, Internet Explorer, Firefox, etc.) typing in the IP address of the pump, indicated in the manual. Once you have completed the connection to the PC, various video pages enable you to fully program the circulator, the digital inputs, the relays etc. and also to display the instant operating parameters, the power consumption and the errors.

#### c) Remote control via Modbus

Some models include an RS-485 connection for communication via **Modbus RTU** protocol.

#### d) Digital inputs and output relays

Some models are equipped with digital inputs and output relays for:

- Switch-on and remote regulation
- Tandem operation (twin)
- Stand-by signals, operation, errors etc.



# GAMMA Ego

## HIGH PERFORMANCE ELECTRONIC CIRCULATORS

in cast iron with cataphoresis coating

### ENERGY LABEL

All Ego models comply with European Directive ErP 2009/125/CE.

With regard to wet-rotor circulators, **the reference parameter is the EEI index (Energy Efficiency Index)**, that identifies the total performance of the pump on a decreasing gradient (or, to the lowest EEI values corresponds a better pump performance).

The due dates provided by the Directive are the following:

- **1<sup>st</sup> step:** starting from **01/01/2013** are allowed only circulators with **EEI ≤ 0,27** (except circulators integrated and for sanitary water)
- **2<sup>nd</sup> step:** starting from **01/08/2015** are allowed only circulators with **EEI ≤ 0,23** (except circulators for sanitary water)
- **3<sup>rd</sup> step:** starting from **01/01/2020** also the circulators on substitution of circulators integrated will have to be **EEI ≤ 0,23** (except circulators for sanitary water)

The technical data sheets of the products indicate the EEI index for every model (value also specified on product nameplate in compliance with specific regulations).

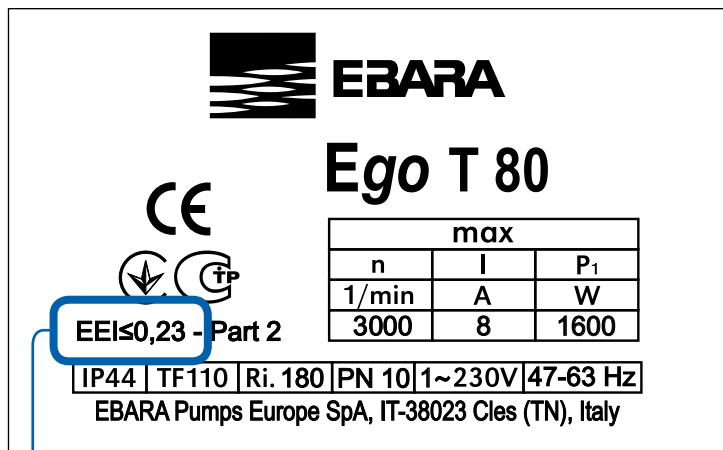

EXAMPLE OF NAMEPLATE WITH EEI INDEX

I contenuti della presente pubblicazione non devono essere considerati ingiuriali. EBARA Pumps Europe SpA si riserva il diritto di apportare senza preavviso le modifiche che riterrà più opportune.

## HIGH PERFORMANCE ELECTRONIC CIRCULATORS

in cast iron with cataphoresis coating

### CONTROL MODE

Below are described all control modes available within the Ego range. Depending on the model, control modes may be available entirely or partly. Therefore, please refer to the data sheets of every model to check the available control modes.

#### a) AUTO (factory setting, where provided)

In this mode **the pump automatically adjusts hydraulic performance** according to the actual requirements of the system, measuring the optimal H/Q point permanently. The AUTO mode is a form of proportional pressure regulation in which the curves have a fixed origin ( $H_{min}$ ); the circulator will work according to system requirements in any point of the area highlighted in the figure, where both  $H_{min}$  and  $H_{max1}$  as well as  $H_{max2}$  are factory settings. **This operating mode is suitable for most applications and ensures high energy savings.**

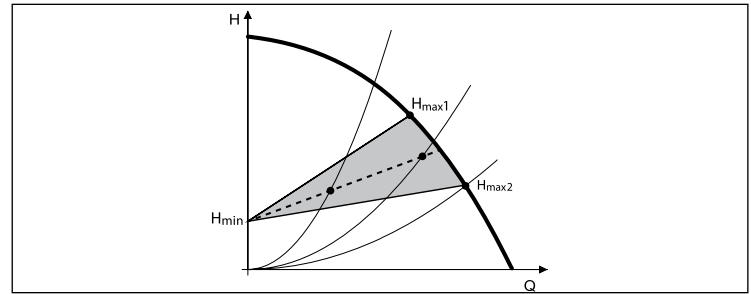

#### b) Proportional pressure ( $\Delta p-v$ )

In this mode, the pump automatically adjusts the pressure depending on the flow rate requested by the system, varying it linearly from a minimum to a maximum value. In practice: **when the flow rate requested increases, the differential pressure generated by the pump is increased as well, and vice versa.** This adjustment is **recommended for systems with high pressure drops.** For smaller models, the work curves ( $H_{min}$ - $H_{max}$ ) are preset, while for greater models they can be set within a wide range.

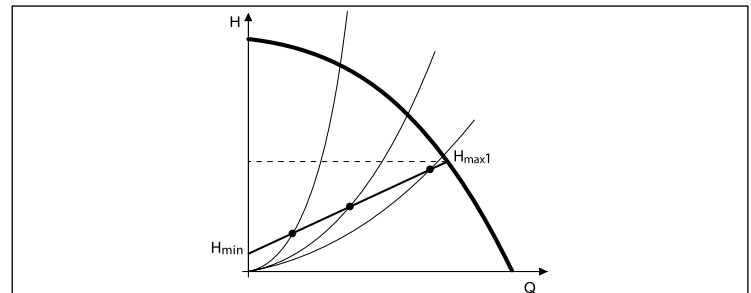

#### c) Constant pressure ( $\Delta P-c$ )

In this mode **the pump head is maintained constant** (equal to the value set by the user) **regardless of the flow rate.** This mode, **recommended in systems with reduced pressure drops,** is available starting from medium sizes and enables selecting the desired pressure  $H_{set}$  (in metres) within a wide range.

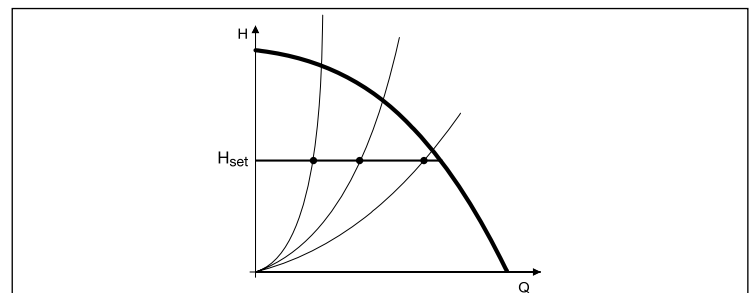

#### d) Constant speed

In this mode **the pump works according to a steady curve** like a common pump without regulation.

You can set various speeds or different constant work curves. In smaller models, the available curves are preset, while in greater models they can be set within a wide range (by setting the desired rotation speed in rpm).

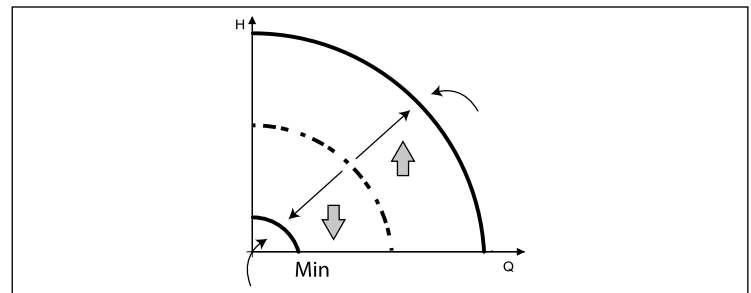

# GAMMA Ego

## HIGH PERFORMANCE ELECTRONIC CIRCULATORS

in cast iron with cataphoresis coating

### PERFORMANCE RANGE

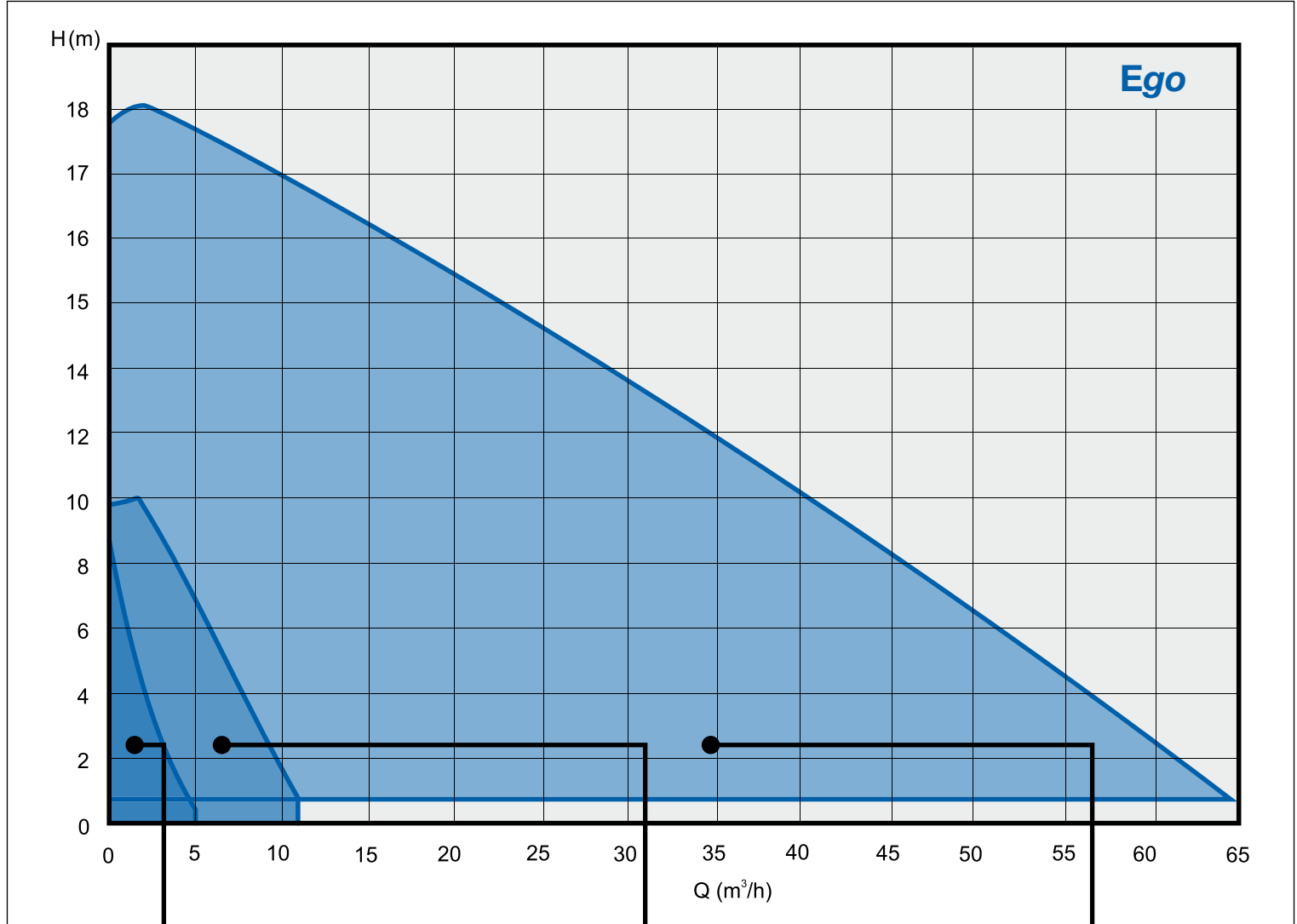

**THREADED CIRCULATORS**  
Ego (T) (ER) -/40, -/60, -/80



**THREADED/FLANGED CIRCULATORS**  
Ego easy (T) (C) -60, -80, -100



**FLANGED CIRCULATORS**  
Ego (T) (C) 50, 65, 80, 100  
Ego (T) (C) slim 40, 50

I contenuti della presente pubblicazione non devono essere considerati ingratificati. EBARA Pumping Europe S.p.A. si riserva il diritto di apportare senza preavviso le modifiche che riterrà più opportune.

# Ego

## THREADED CIRCULATORS

Ego (T) (ER) -/40, -/60, -/80, single and twin



High performance wet-rotor circulation pump with threaded connection, motor with permanent magnets and built-in electronic controller.

### APPLICATIONS

Impianti domestici di riscaldamento e condizionamento.

### PARTICOLARITÀ

- Built-in frequency converter
- Two operating modes ("ΔP-v" and "constant speed")
- Automatic venting function
- High input torque (with consequent automatic release of the rotor)
- Easy installation and adjustment by means of a single LED button
- 0-10V contact (optional, see versions "ER")

### DATI TECNICI POMPA

- Liquid temperature: +5 ÷ +95 °C
- Room temperature: 0 ÷ +40 °C
- Relative air humidity: ≤ 95%
- Allowed fluids: clean, non aggressive and not flammable, free of solid particles or fibres
- Maximum pressure: 10 bar
- Minimum suction pressure:
  - 0,05 bar at 50 °C
  - 0,4 bar at 80 °C
  - 1,1 bar at 110 °C
- Maximum amount of glycol: 20%\*
- Threaded inlets: G 1" – 1 1/2" – 2" (in accordance with ISO 228)
- Protection degree: IP44

### DATI TECNICI MOTORE

- Type: synchronous with permanent magnets
- Motor speed: variable
- Supply voltage: 1~230V
- Frequency: 50/60 Hz
- Insulation class: F

\* For greater amounts please check the final viscosity and the conditions of use

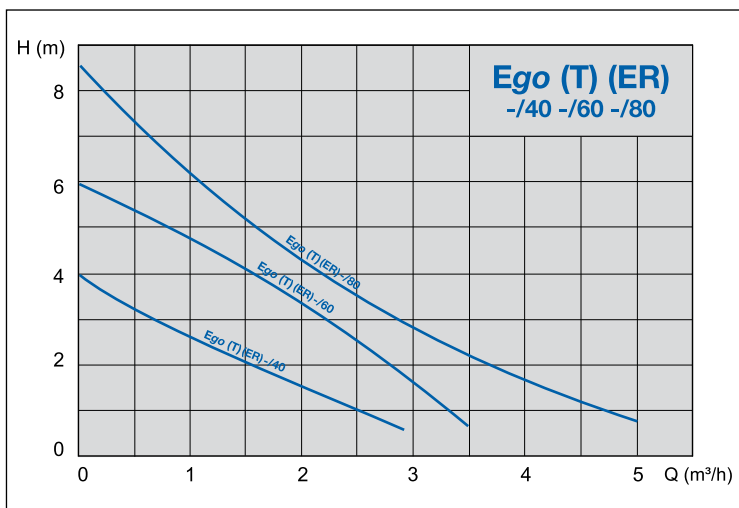

### IDENTIFICATION CODE

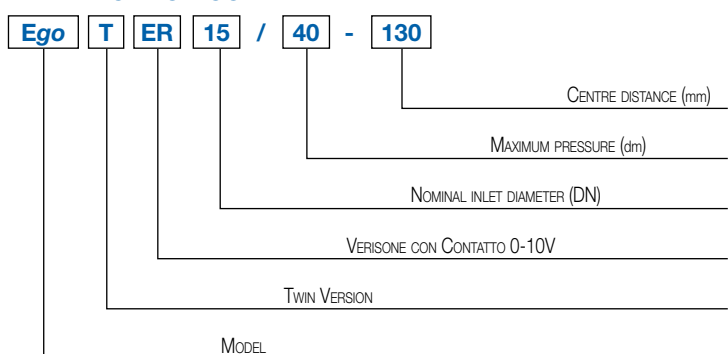

### IDENTIFICATION CODE

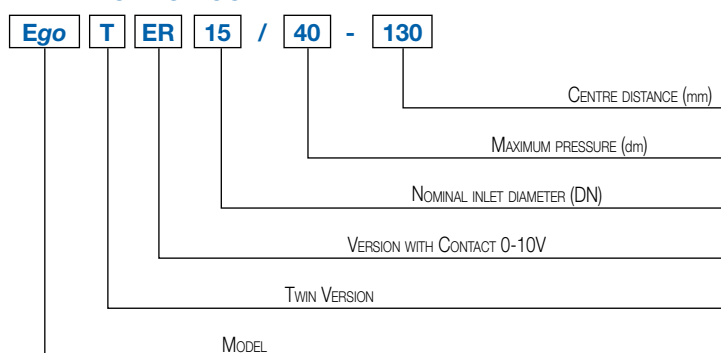



## THREADED CIRCULATORS

Ego (T) (ER) -/40, -/60, -/80, single and twin

### OPERATING MODES

Two operating modes that can be selected using the LED button located on terminal box:

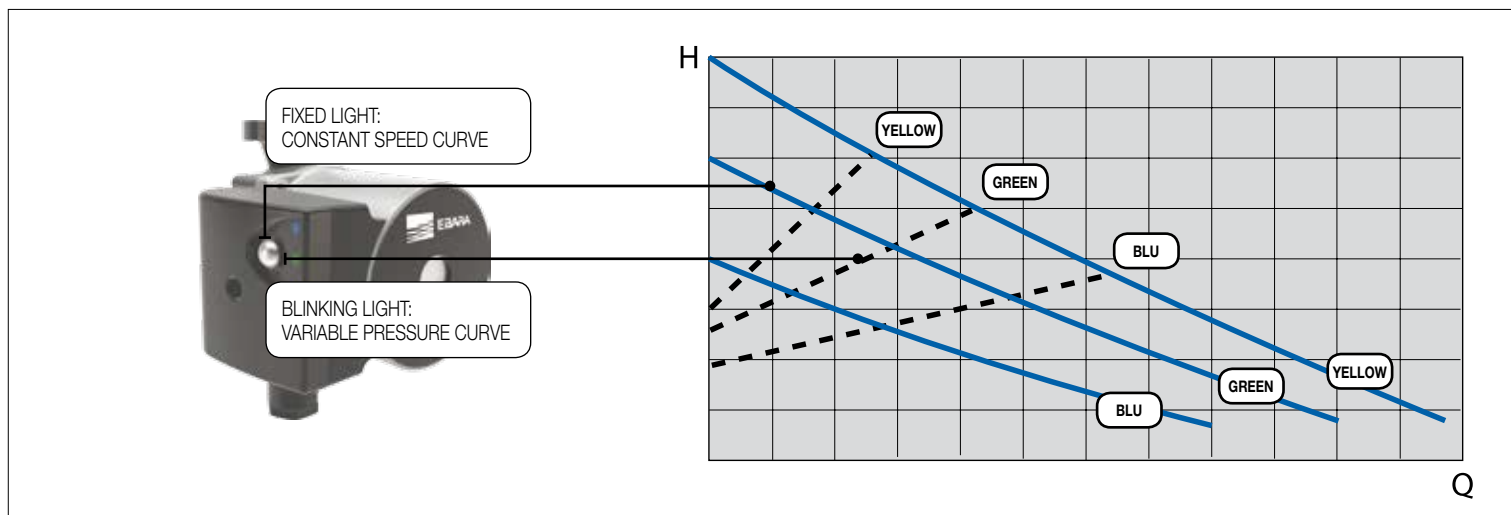

#### • $\Delta P$ -v Proportional pressure (factory setting)

The circulators of this range can work in variable pressure **mode on 3 preset curves**. When this operating mode is enabled **the LED button blinks**, with a frequency that varies according to instant flow rate. **The colour of the LED identifies the selected curve** ("blue" indicates the lowest curve, "green" the intermediate curve, while "yellow" indicates the highest curve); to switch from one curve to another just press the button briefly.

From variable pressure modes (LED blinking) you can switch to constant speed mode (LED light steadily lit) keeping the LED button pressed for at least 5 seconds.

#### • Constant speed

The circulators of this range can work at constant speed **on 3 preset curves**. In this case, the pump works as a usual pump without regulation and the power consumption remains constant. When this mode is active **the LED remains steadily lit**; in this case the colour of the LED **indicates the selected curve** ("blue" the lowest curve, "green" the intermediate curve, and "yellow" the highest curve). To switch from one curve to another, briefly press the button to return to variable pressure mode, select the desired curve (indicated by the colour of the LED) and then press and hold down the button.

### VERSIONS WITH ANALOG REGULATION 0-10V (mod. Ego ER -/40, -/60, -/80)

The special versions **Ego ER**, equipped with 0-10V contact inside the terminal box, enable setting the desired work curve remotely (both the fixed speed and the variable differential pressure). In this case, as shown in the diagrams below, the work curves are more numerous.

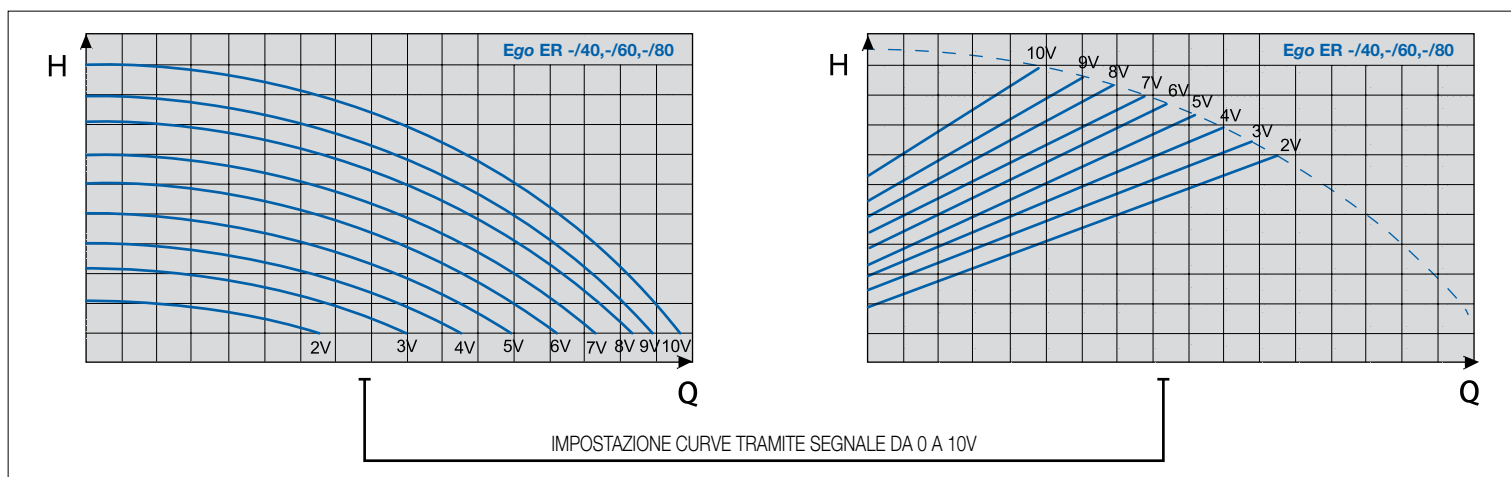

## THREADED CIRCULATORS

Ego (T) (ER) -/40, -/60, -/80, single and twin

### PERFORMANCE CURVES

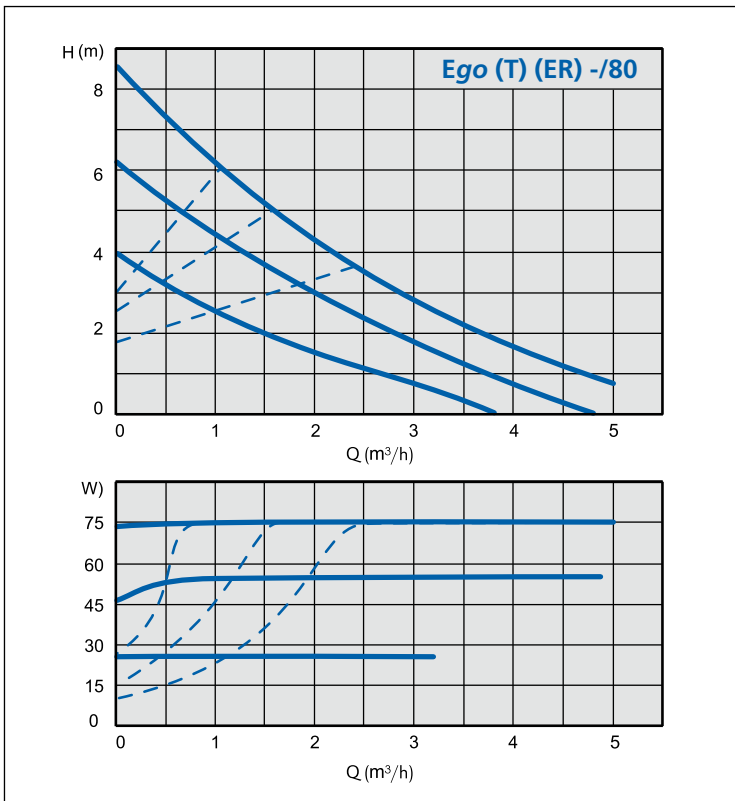
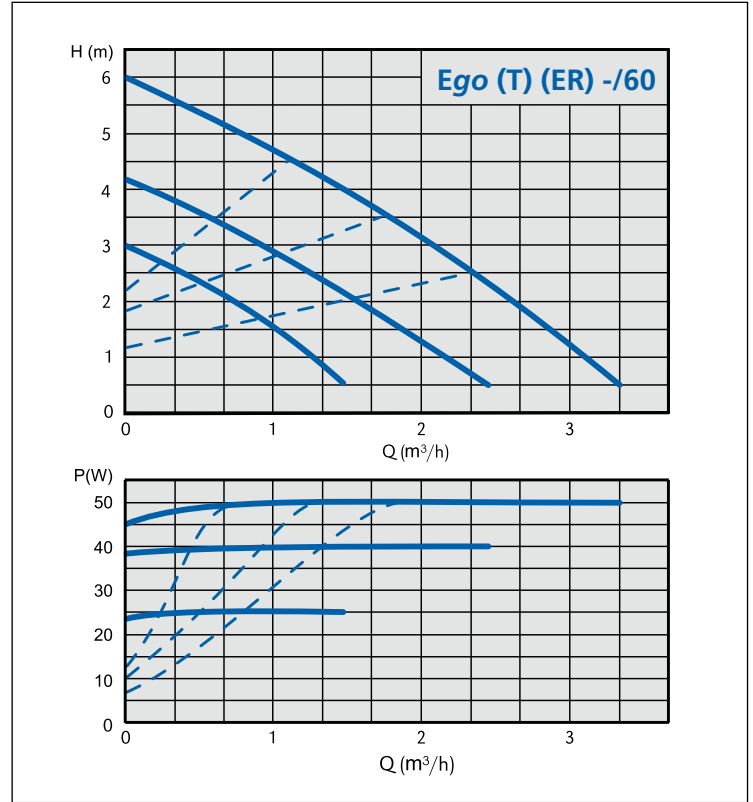
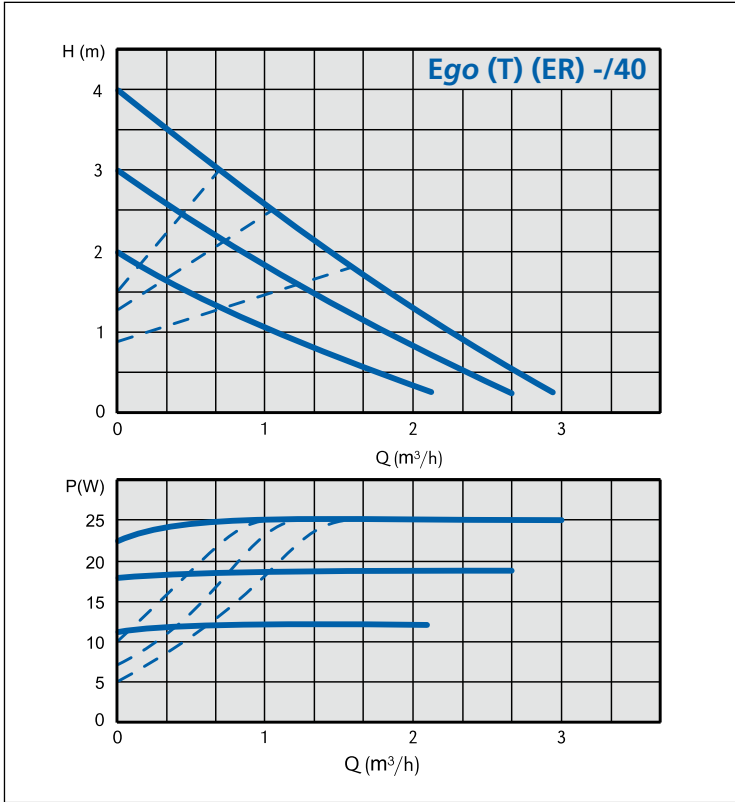

## THREADED CIRCULATORS

Ego (T) (ER) -/40, -/60, -/80, single and twin

### SECTIONAL VIEW

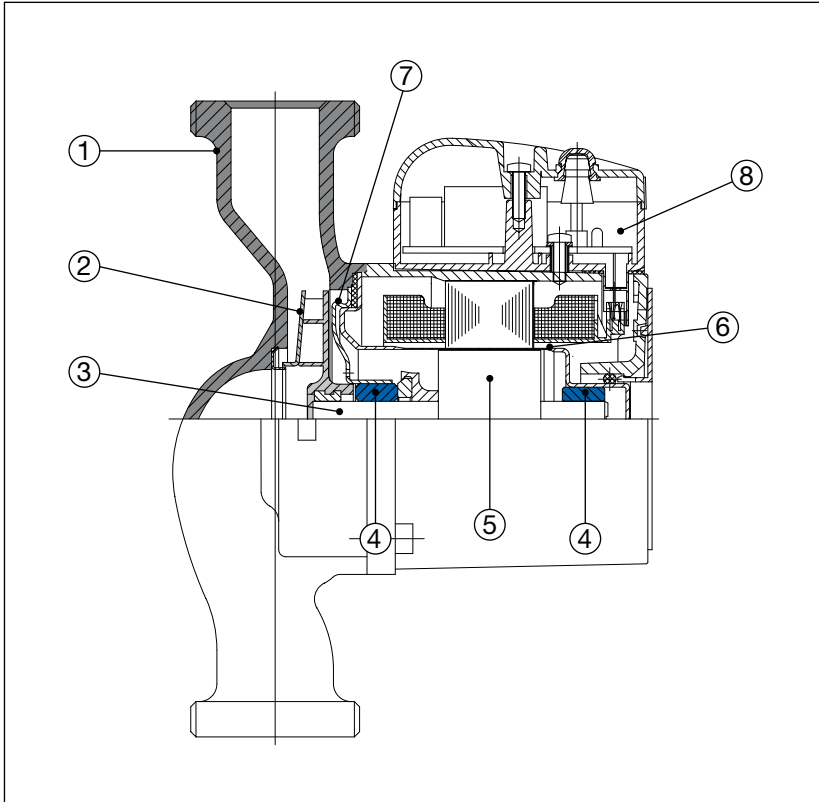

### MATERIAL TABLE

Ref.	Part	Material
1	Pump body	Cast iron with cataphoresis coating
2	Impeller	Technopolymer
3	Shaft	Ceramic
4	Bearings	Ceramic
5	Rotor	Rivestito in acciaio INOX
6	Rotor can	AISI 316 Stainless Steel
7	Bearing plate	AISI 316 Stainless Steel
8	Electronic board	-

### TECHNICAL FEATURES - single

Model	EEl (energy efficiency index)	Pipe connection	Inlet fitting	Power P <sub>1</sub> [W] P <sub>max</sub>	Current consumption [A] I <sub>min</sub> - I <sub>max</sub>	Weight [kg]
Ego (ER) 15/40-130	≤ 0,15	G1	Rp ½"	25	0,05 ÷ 0,2	1,9
Ego (ER) 25/40-130	≤ 0,15	G1½"	Rp 1"	25	0,05 ÷ 0,2	2,1
Ego (ER) 15/60-130	≤ 0,17	G1	Rp ½"	50	0,05 ÷ 0,4	1,9
Ego (ER) 25/60-130	≤ 0,17	G1½"	Rp 1"	50	0,05 ÷ 0,4	2,1
Ego (ER) 25/80-130	≤ 0,19	G1½"	Rp 1"	75	0,05 ÷ 0,6	2,1
Ego (ER) 25/40-180	≤ 0,15	G1½"	Rp 1"	25	0,05 ÷ 0,2	2,4
Ego (ER) 32/40-180	≤ 0,15	G2	Rp 1"¼"	25	0,05 ÷ 0,2	2,5
Ego (ER) 25/60-180	≤ 0,17	G1½"	Rp 1"	50	0,05 ÷ 0,4	2,4
Ego (ER) 32/60-180	≤ 0,17	G2	Rp 1"¼"	50	0,05 ÷ 0,4	2,5
Ego (ER) 25/80-180	≤ 0,19	G1½"	Rp 1"	75	0,05 ÷ 0,6	2,4
Ego (ER) 32/80-180	≤ 0,19	G2	Rp 1"¼"	75	0,05 ÷ 0,6	2,5

### TECHNICAL FEATURES - twin

Model	EEl (energy efficiency index)	Pipe connection	Inlet fitting	Power P <sub>1</sub> [W] P <sub>max</sub>	Current consumption [A] I <sub>min</sub> - I <sub>max</sub>	Weight [kg]
Ego T 25/60-180	≤ 0,17	G1½"	Rp 1"	50	0,05 ÷ 0,4	5,5
Ego T 32/60-180	≤ 0,17	G2	Rp 1"¼"	50	0,05 ÷ 0,4	5,5
Ego T 25/80-180	≤ 0,19	G1½"	Rp 1"	75	0,05 ÷ 0,6	5,7
Ego T 32/80-180	≤ 0,19	G2	Rp 1"¼"	75	0,05 ÷ 0,6	5,7

## THREADED CIRCULATORS

Ego -/40, -/60, -/80

### DIMENSIONS - singles

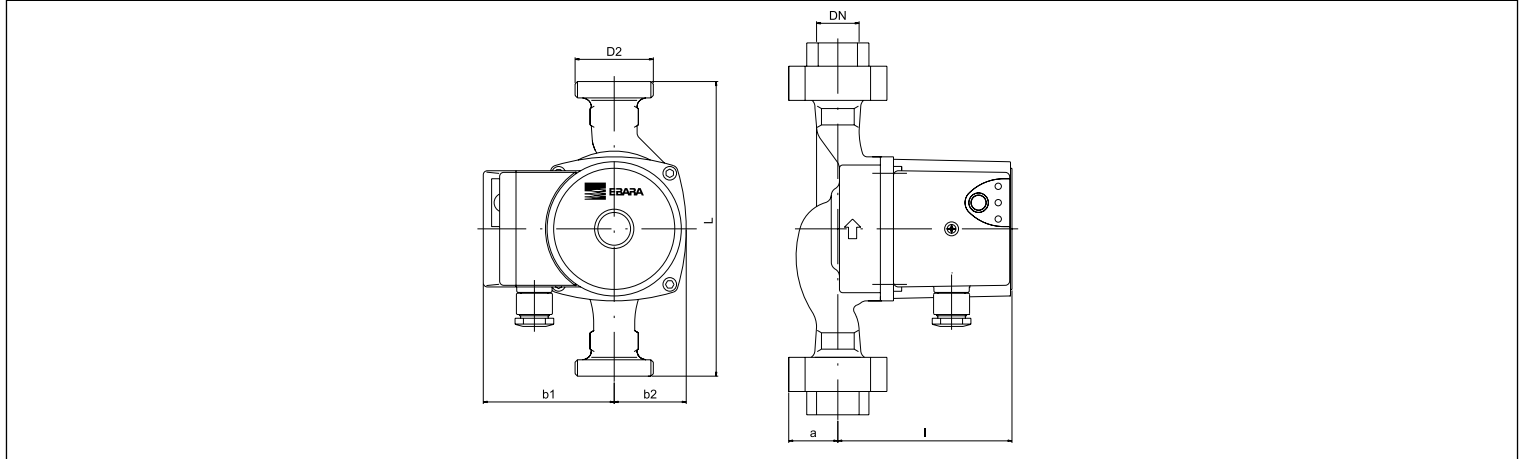

### DIMENSIONS TABLE - singles

Model	Dimensions [mm]						
	L	DN	b1	b2	l	a	D2
Ego (ER) 15/40-130	130	15	80	48	108	27	1"
Ego (ER) 25/40-130	130	25	80	48	108	32	1 1/2"
Ego (ER) 15/60-130	130	15	80	48	108	27	1"
Ego (ER) 25/60-130	130	25	80	48	108	32	1 1/2"
Ego (ER) 25/80-130	130	25	80	48	108	32	1 1/2"
Ego (ER) 25/40-180	180	25	80	48	108	32	1 1/2"
Ego (ER) 32/40-180	180	32	80	48	108	40	2"
Ego (ER) 25/60-180	180	25	80	48	108	32	1 1/2"
Ego (ER) 32/60-180	180	32	80	48	108	40	2"
Ego (ER) 25/80-180	180	25	80	48	108	32	1 1/2"
Ego (ER) 32/80-180	180	32	80	48	108	40	2"

### DIMENSIONS - twin

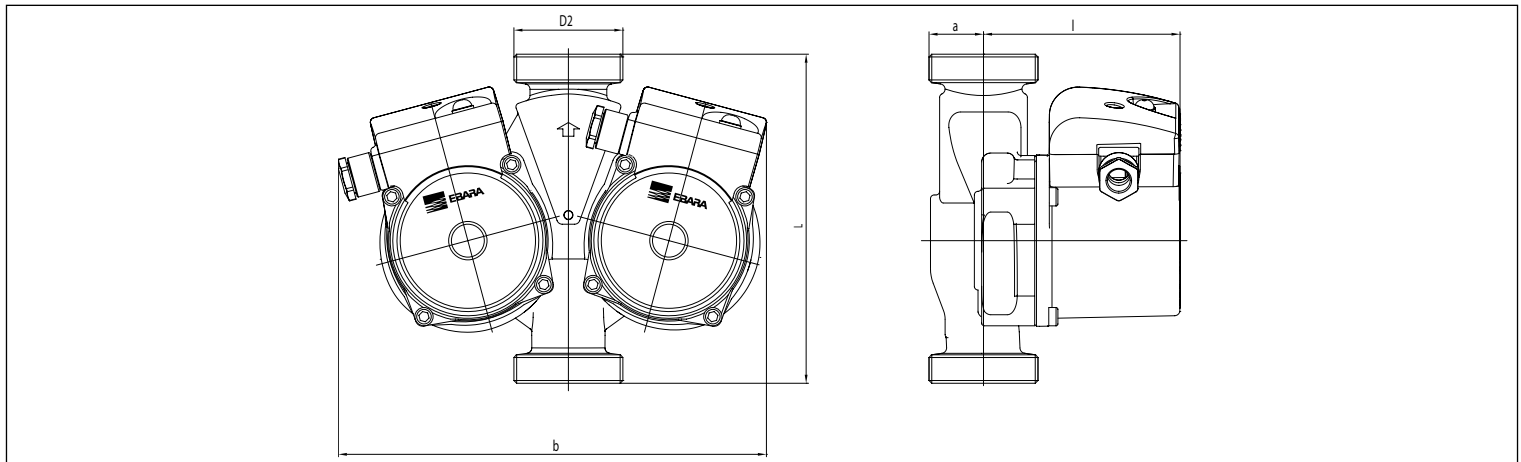

### DIMENSIONS TABLE- twin

Model	Dimensions [mm]						
	L	DN	b	l	a	D2	
Ego T 25/80-180	180	25	234	107,2	29,8	1 1/2"	
Ego T 32/80-180	180	32	234	107,2	29,8	2"	
Ego T 25/60-180	180	25	234	107,2	29,8	1 1/2"	
Ego T 32/60-180	180	32	234	107,2	29,8	2"	

## THREADED CIRCULATORS

Ego -/40, -/60, -/80

### ASSEMBLY POSITION

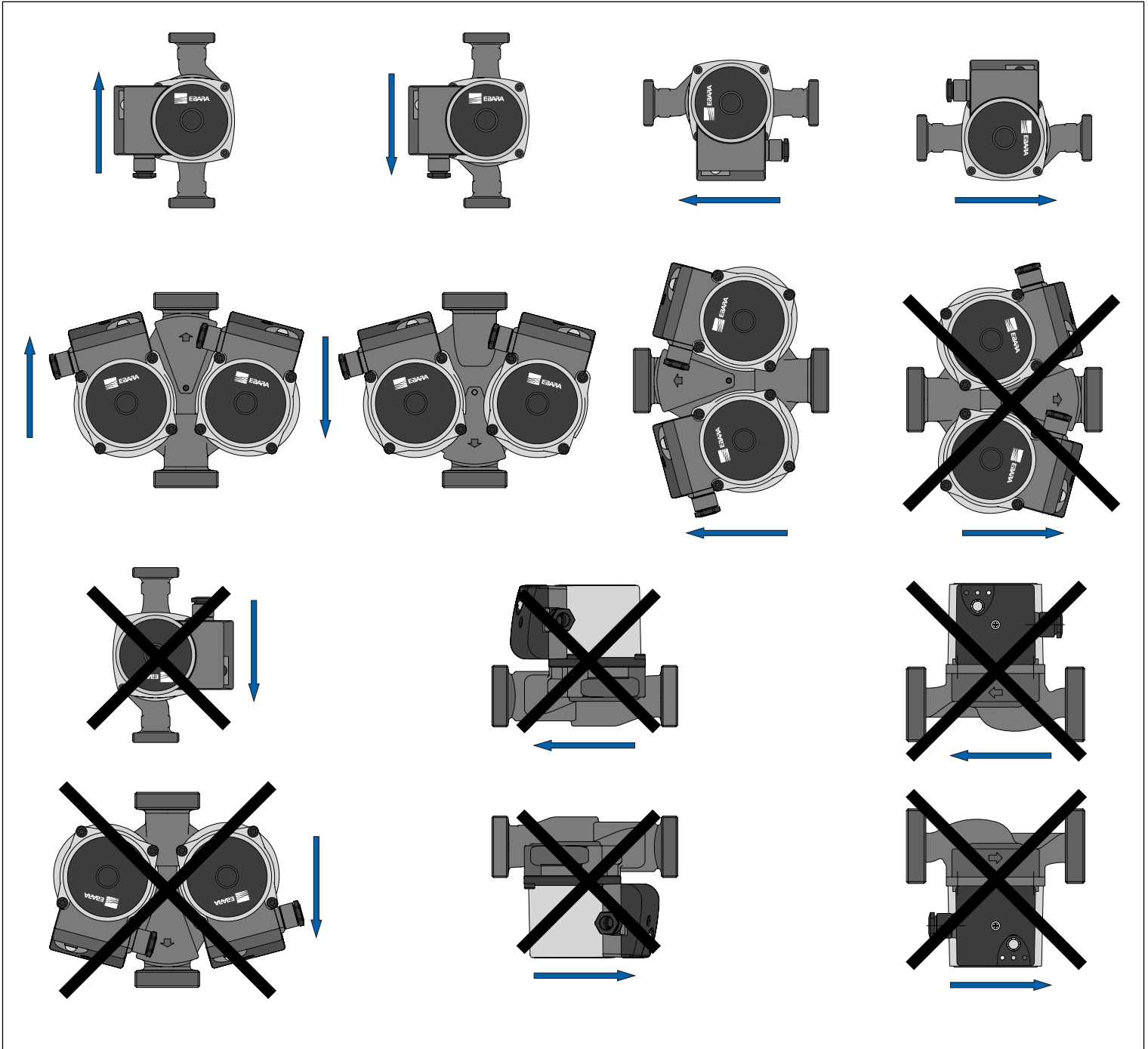

# Ego easy

## THREADED/FLANGED CIRCULATORS

Ego (T) (C) easy -60, -80, -100, -120 single and twin



High performance wet rotor circulation pump with threaded or flanged connection, motor with permanent magnets and built-in electronic controller.

### APPLICATION

Residential and industrial heating and air-conditioning systems.

### FEATURES

- Built-in frequency converter
- Multiple operating modes
- Numeric and graphical display for easy setup and visualisation of parameters
- Automatic venting function
- Built-in overload safety device
- High input torque (with consequent automatic release of the rotor)
- Optional communication module (with Ethernet port, 0-10V contact, digital inputs etc.)

### PUMP TECHNICAL DATA

- Liquid temperature:  $+2 \div +110$  °C
- Room temperature:  $0 \div +40$  °C
- Relative air humidity:  $\leq 95\%$
- Allowed fluids: clean, non aggressive and not flammable, free of solid particles or fibres
- Maximum pressure: 10 bar
- Minimum suction pressure:
  - 0,05 bar to 50 °C
  - 0,8 bar to 80 °C
  - 1,4 bar to 110 °C
- Maximum amount of glycol: 20%\*
- Threaded inlets: G 1 1/2" – 2" (in accordance with ISO 228)
- Flanged inlets: from DN 32 to DN 50
- Protection degree: IP44

### MOTOR TECHNICAL DATA

- Type: synchronous with permanent magnets
- Motor speed: variable
- Supply voltage: 1~230V
- Frequency: 50/60 Hz
- Insulation class: F

\* For greater amounts please check the final viscosity and the conditions of use.

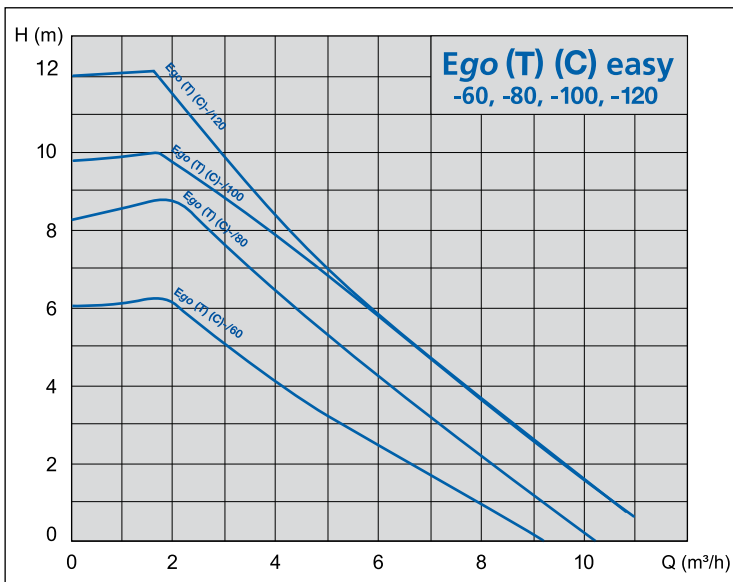

### IDENTIFICATION CODE

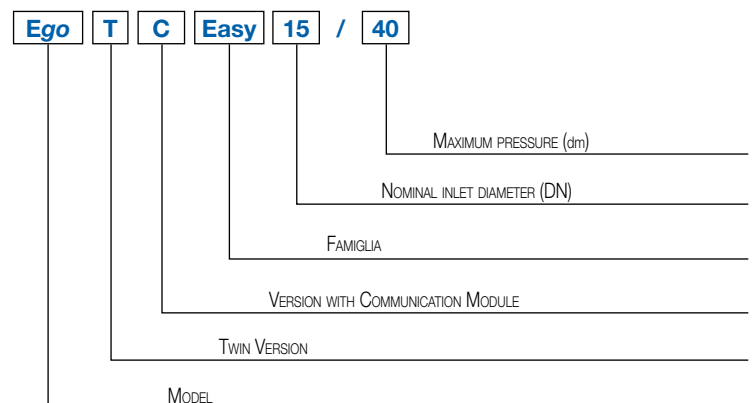

## THREADED/FLANGED CIRCULATORS

Ego (T) (C) easy -60, -80, -100, -120 single and twin

### OPERATING MODES

The operating modes can be selected using the buttons located on the rear panel:

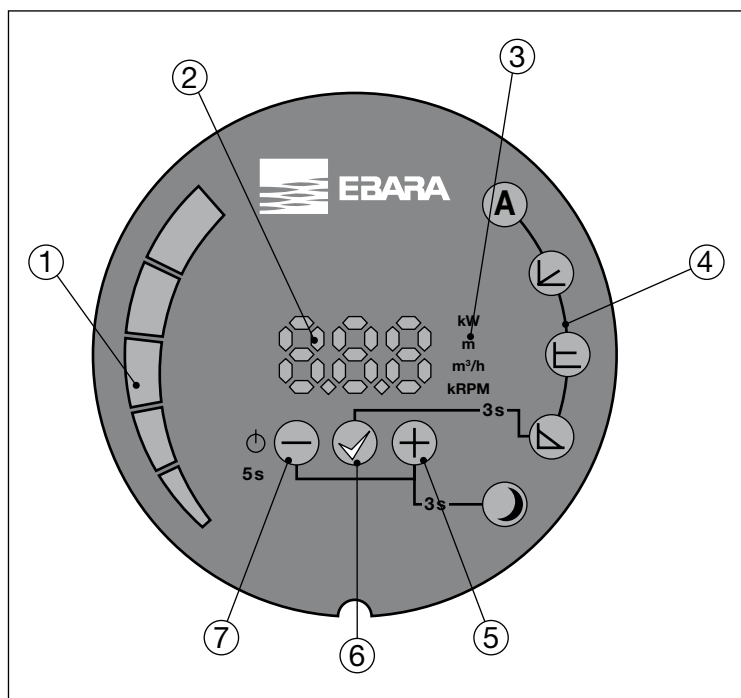

### KEY

- 1 Segment display
- 2 Numeric display
- 3 Display of selected parameter
- 4 Display of selected mode
- 5 Selection key
- 6 Confirmation key
- 7 Selection key

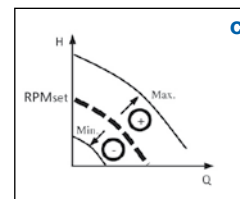
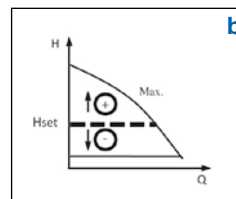
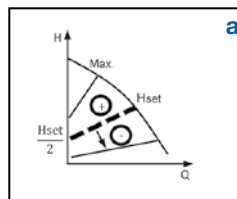

### AUTO mode (factory setting)

The circulator automatically adjusts the hydraulic performance depending on the actual requirements of the system, continuously measuring the optimal H/Q point. This operating mode is suitable for most applications and ensures high energy savings.



### Proportional pressure ( $\Delta P-v$ ) - fig. a

The circulator adjusts the pump head depending on the flow rate, varying the latter linearly from a maximum value ( $H_{set}$ ) to a minimum value (equal to  $H_{set}/2$ ). The pressure value ( $H_{set}$ ) is set via buttons  $\oplus$  and  $\ominus$  and is expressed in metres; the minimum value is automatically calculated by the circulator.



### Constant pressure ( $\Delta P-c$ ) - fig. b

The circulators maintains the pump head constant when the flow rates varies. The value of the pressure ( $H_{set}$ ) is set via buttons  $\oplus$  and  $\ominus$  and is expressed in metres.



### Constant speed - fig. c

The circulators operates according to a constant curve set via buttons  $\oplus$  and  $\ominus$  (by selecting the rotation speed in "rpm").



### Night mode

Night mode can be activated in combination with any of the operating modes listed above, and allows the circulator to operate at a minimum curve (therefore with very low consumption) when it detects a decrease in liquid temperature of 15-20 ° C. When temperature rises, it automatically returns to normal operating curve (according to the selected mode).

# Ego easy

## THREADED/FLANGED CIRCULATORS

Ego (T) (C) easy -60, -80, -100, -120 single and twin

### COMMUNICATION MODULE

Versions **Ego T C easy** are equipped with an additional communication module which can be accessed by opening the rear display panel. The communication module is also available as an optional accessory. It is compatible with all standard models Ego easy. The module enables running a wide range of applications remotely:

- Access via Ethernet
- Remote On/Off
- Analog control 0-10V
- Modbus RTU
- Alarm/state relay

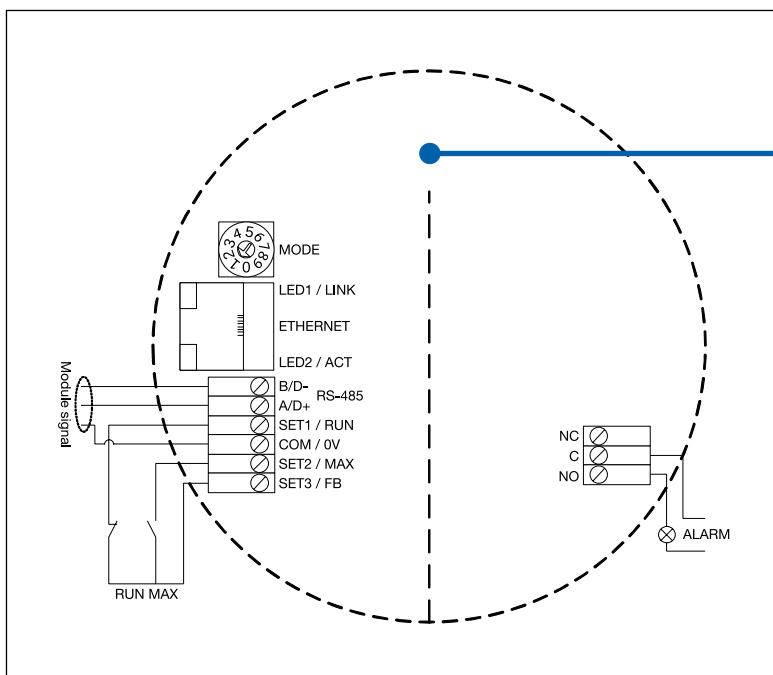
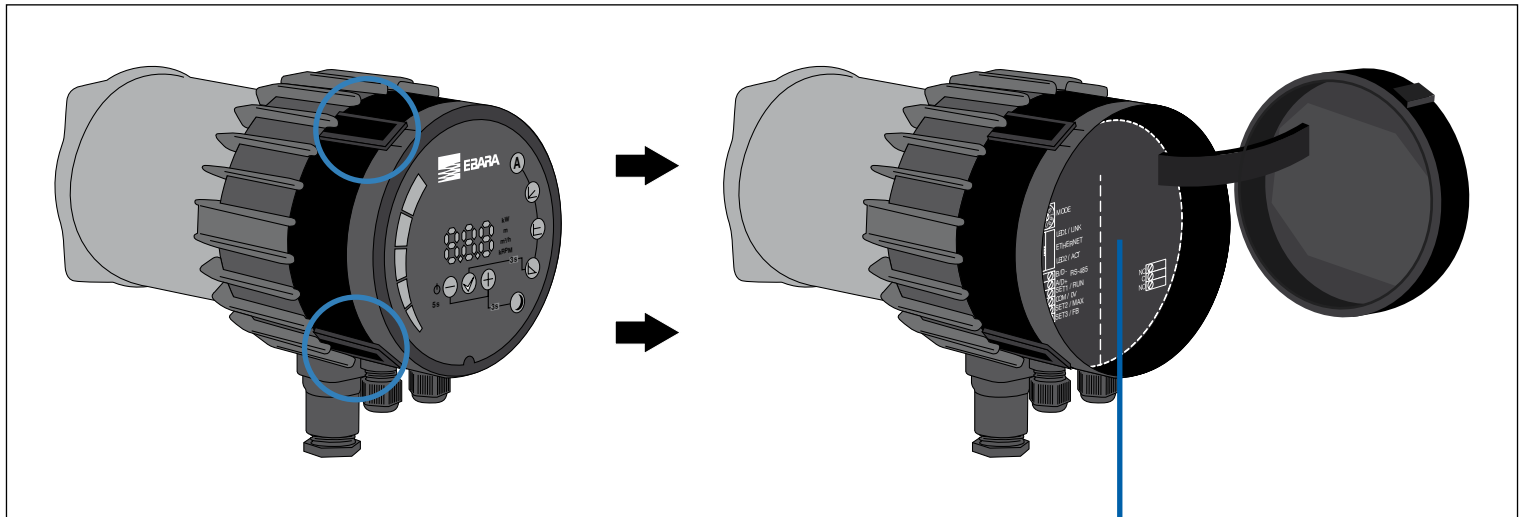



# Ego easy

## THREADED/FLANGED CIRCULATORS

Ego (T) (C) easy -60, -80, -100, -120 single and twin

### PERFORMANCE CURVES

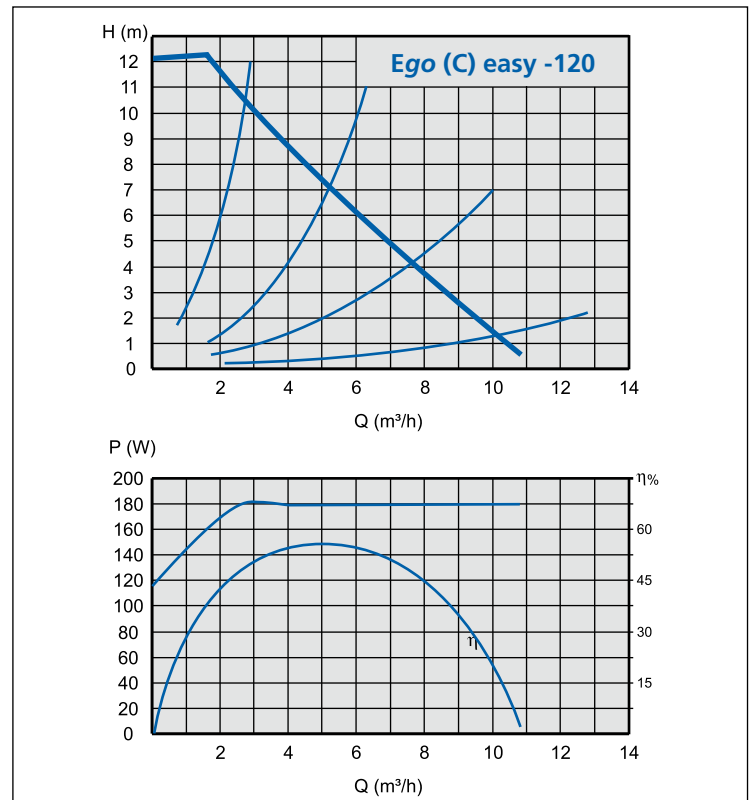
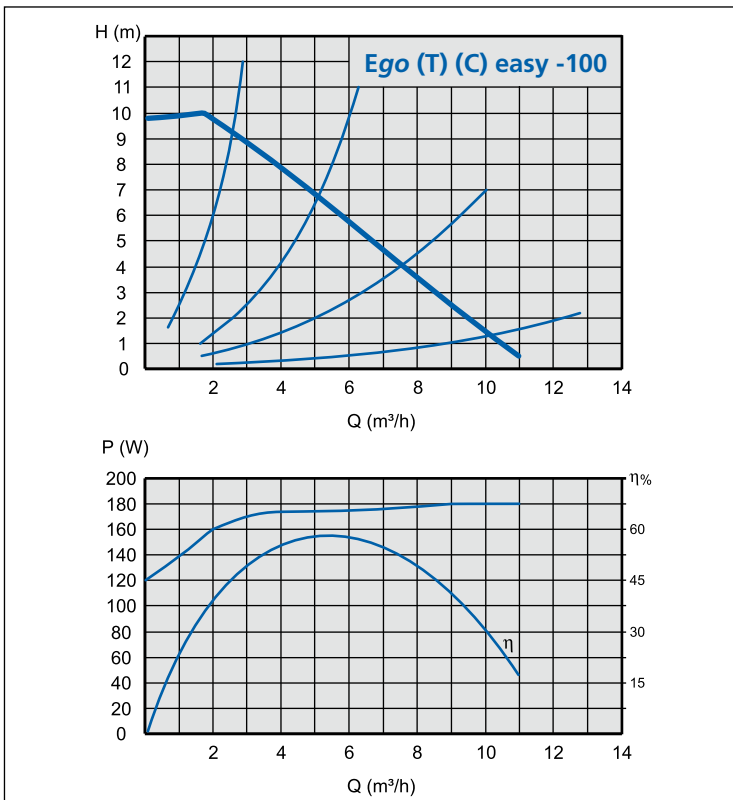
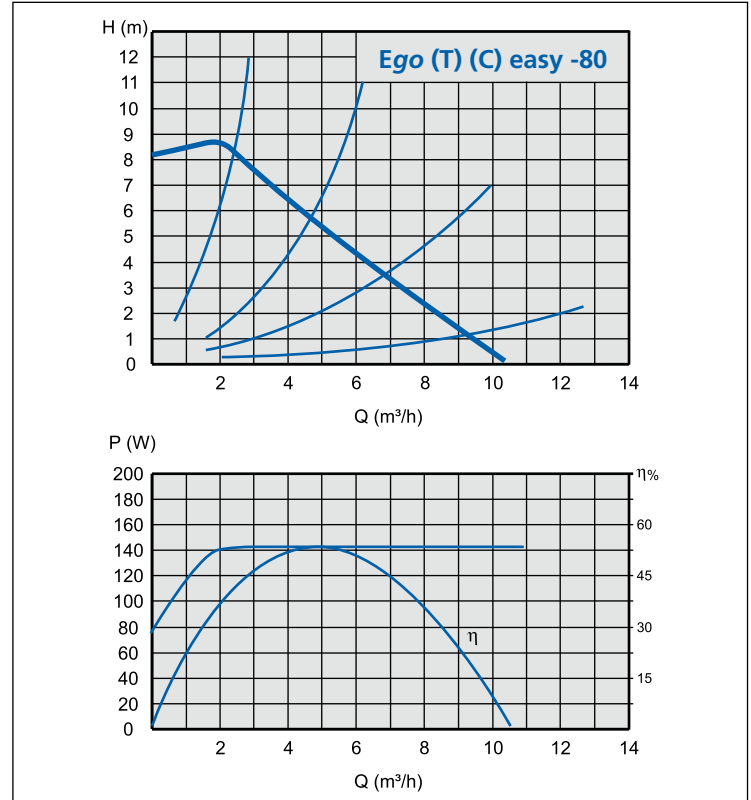
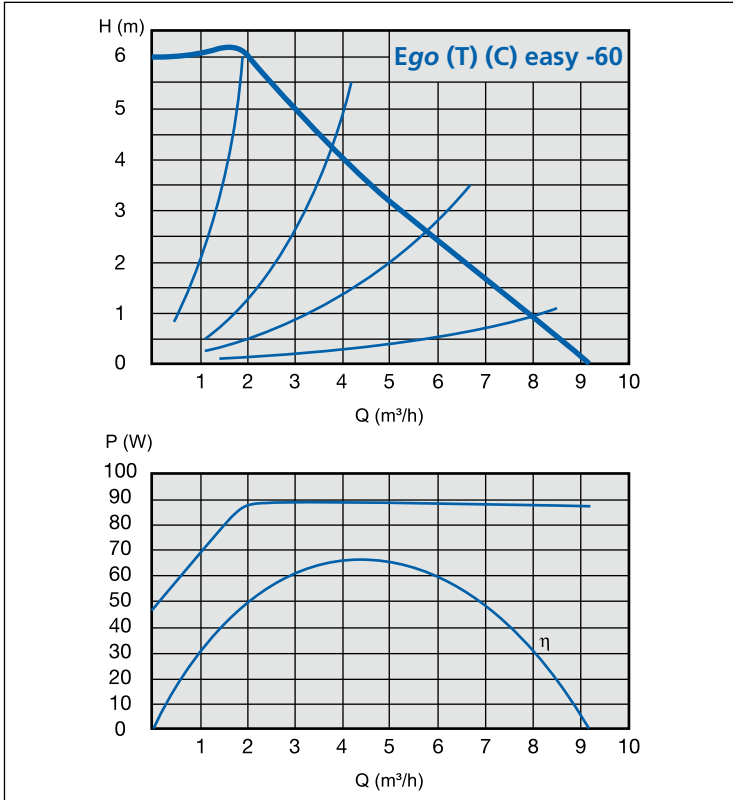

I contenuti della presente pubblicazione non devono essere considerati ingaranti. EBARA, Pumps Europe S.p.A. si riserva il diritto di apportare senza preavviso le modifiche che riterrà più opportune.

# Ego easy

## THREADED/FLANGED CIRCULATORS

Ego (T) (C) easy -60, -80, -100, -120 single and twin

### SECTIONAL VIEW

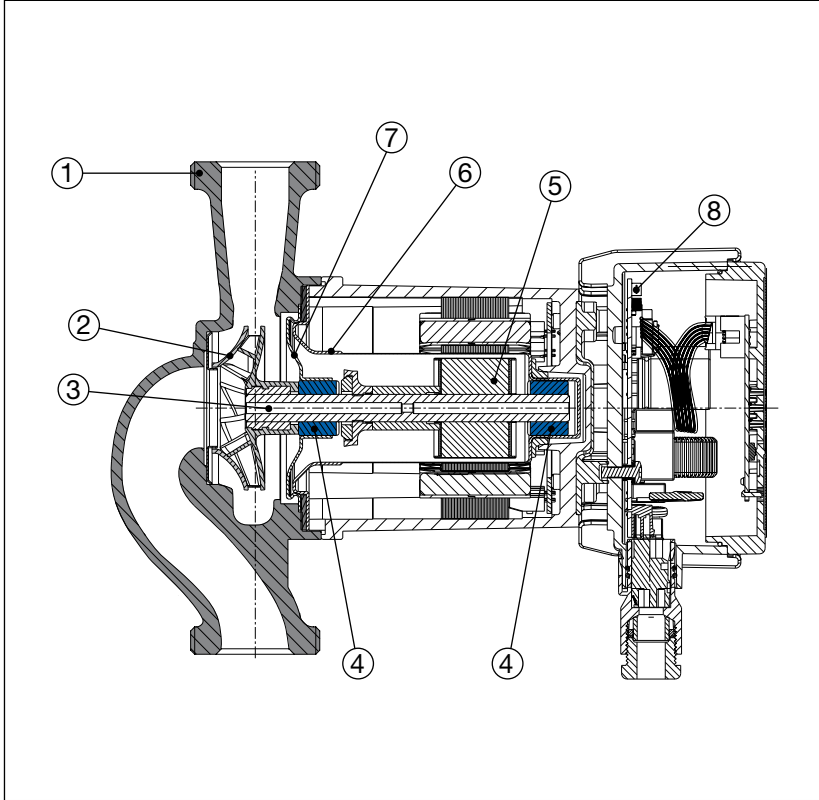

### MATERIAL TABLE

Ref.	Part	Material
1	Pump body	Cast iron with cataphoresis coating
2	Impeller	Technopolymer
3	Shaft	Stainless steel
4	Bearings	Graphite
5	Rotor	Coated in stainless steel
6	Rotor can	AISI 316 Stainless Steel
7	Bearing plate	AISI 316 Stainless Steel
8	Electronic board	-

### TECHNICAL FEATURES - single

Model	EEl (energy efficiency index)	Pipe connection	Inlet fitting	Power $P_1$ [W] $P_{max}$	Current consumption [A] $I_{min} - I_{max}$	Weight [kg]
Ego easy 25-60	$\leq 0,21$	G1 1/2"	Rp 1"	90	0,1 ÷ 0,75	4,0
Ego easy 32-60	$\leq 0,21$	G2"	Rp 1 1/4"	90	0,1 ÷ 0,75	4,1
Ego easy 25-80	$\leq 0,21$	G1 1/2"	Rp 1"	140	0,1 ÷ 1,15	4,0
Ego easy 32-80	$\leq 0,21$	G2"	Rp 1 1/4"	140	0,1 ÷ 1,15	4,1
Ego easy 25-100	$\leq 0,21$	G1 1/2"	Rp 1"	180	0,1 ÷ 1,5	4,0
Ego easy 32-100	$\leq 0,21$	G2"	Rp 1 1/4"	180	0,1 ÷ 1,5	4,1
Ego easy 25-120	$\leq 0,22$	G1 1/2"	Rp 1 1/2"	180	0,1 ÷ 1,5	4,0
Ego easy 32-120	$\leq 0,22$	G2"	Rp 2"	180	0,1 ÷ 1,5	4,1
Ego easy 32-100F	$\leq 0,21$	DN 32	-	180	0,1 ÷ 1,5	7,4
Ego easy 40-100F	$\leq 0,21$	DN 40	-	180	0,1 ÷ 1,5	8,5
Ego easy 50-100F	$\leq 0,21$	DN 50	-	180	0,1 ÷ 1,5	9,8

### TECHNICAL FEATURES - twin

Model	EEl (energy efficiency index)	Pipe connection	Inlet fitting	Power $P_1$ [W] $P_{max}$	Current consumption [A] $I_{min} - I_{max}$	Weight [kg]
Ego T C easy 32-60	$\leq 0,21$	G 2"	Rp 1 1/4"	90	0,1 ÷ 0,75	8,2
Ego T C easy 32-80	$\leq 0,21$	G 2"	Rp 1 1/4"	140	0,1 ÷ 1,15	8,2
Ego T C easy 32-100	$\leq 0,21$	G 2"	Rp 1 1/4"	180	0,1 ÷ 1,50	8,2
Ego T C easy 40-100F	$\leq 0,21$	DN 40	-	180	0,1 ÷ 1,50	11,0

# Ego easy

## THREADED/FLANGED CIRCULATORS

Ego (T) (C) easy -60, -80, -100, -120 single and twin

### DIMENSIONS - singles

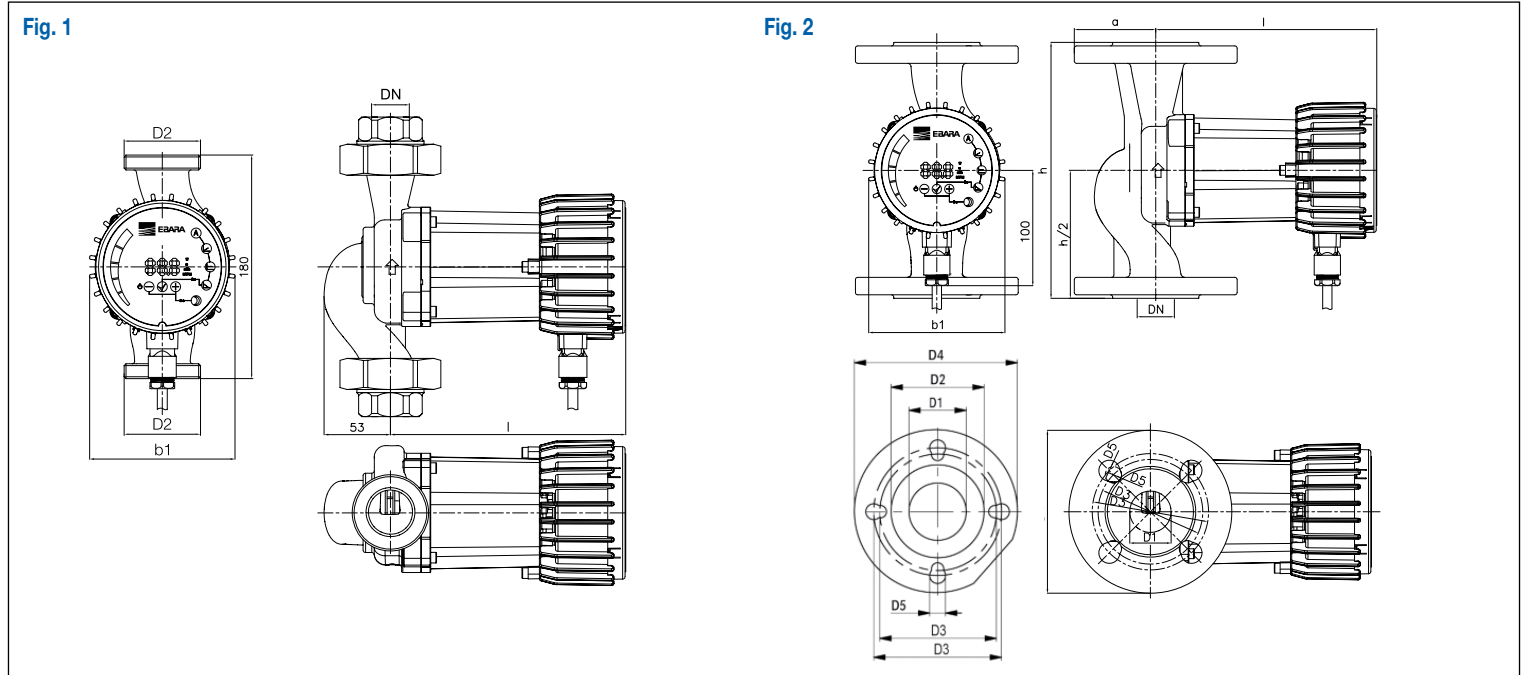

### DIMENSIONS TABLE - singles

Ref.	Model	Dimensions [mm]										
		h	DN	b1	l	a	D1	D2	D3	D4	D5	n° fori
Fig. 1	Ego easy 25-60	180	25	117	190 (222)*	-	-	1"½	-	-	-	-
	Ego easy 32-60	180	32	117	190 (222)*	-	-	2"	-	-	-	-
	Ego easy 25-80	180	25	117	190 (222)*	-	-	1"½	-	-	-	-
	Ego easy 32-80	180	32	117	190 (222)*	-	-	2"	-	-	-	-
	Ego easy 25-100	180	25	117	190 (222)*	-	-	1"½	-	-	-	-
	Ego easy 32-100	180	32	117	190 (222)*	-	-	2"	-	-	-	-
	Ego easy 25-120	180	25	117	190 (222)*	-	-	1"½	-	-	-	-
Fig. 2	Ego easy 32-120	180	32	117	190 (222)*	-	-	2"	-	-	-	-
	Ego easy 32-100F	220	32	117	190 (222)*	70	32	74	90/100	140	14/18	4
	Ego easy 40-100F	220	40	117	190 (222)*	75	40	80	100/110	150	14/19	4
	Ego easy 50-100F	240	50	117	190 (222)*	82,5	50	90	110/125	165	14/19	4

\* Dimensions in bracket are referred to Ego easy with communication module

## THREADED/FLANGED CIRCULATORS

Ego (T) (C) easy -60, -80, -100, -120 single and twin

### DIMENSIONS - twin

Fig. 1

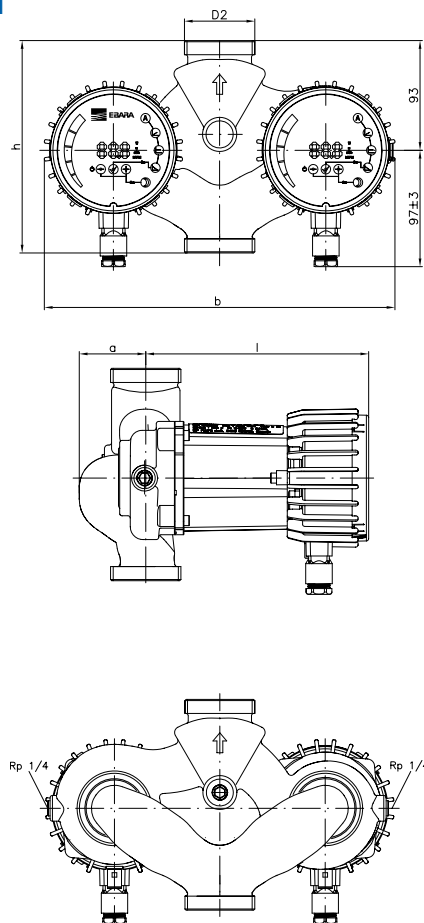
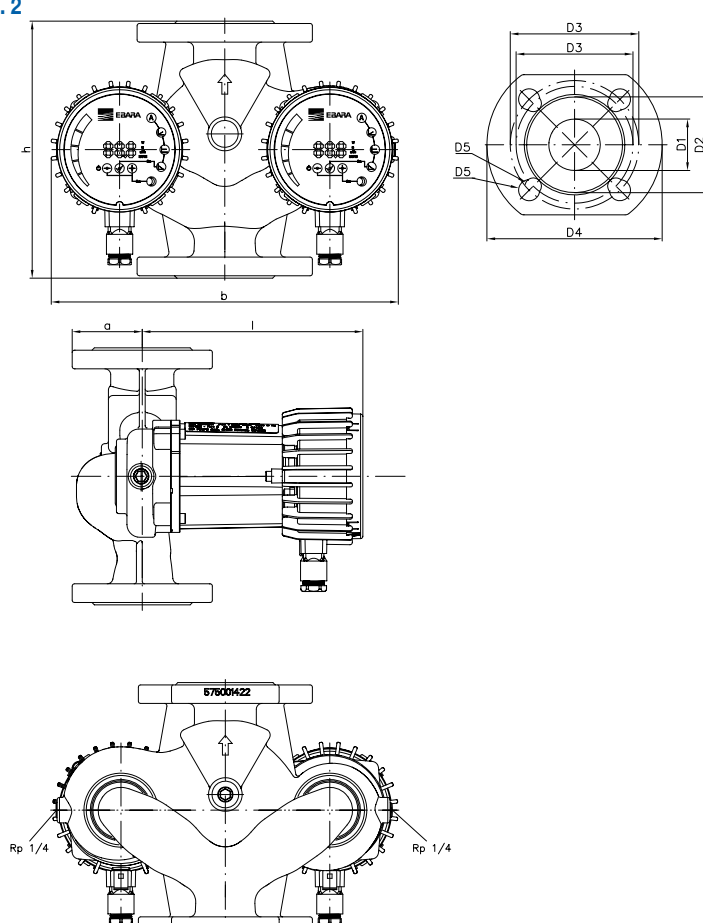

Fig. 2



### DIMENSIONS - twin

Ref.	Model	Dimensions [mm]										
		h	DN	b	l	a	D1	D2	D3	D4	D5	n° fori
Fig. 1	Ego T C easy 32-60	180	32	297	222	56	-	2"	-	-	-	-
	Ego T C easy 32-80	180	32	297	222	56	-	2"	-	-	-	-
	Ego T C easy 32-100	180	32	297	222	56	-	2"	-	-	-	-
Fig. 2	Ego T C easy 40-100F	220	40	297	222	75	40	80	100/110	150	14/19	4

\* Communication module is supplied on twin standard version

# Ego

## THREADED/FLANGED CIRCULATORS

Ego (T) (C) easy -60, -80, -100, -120 single and twin

### ASSEMBLY POSITION

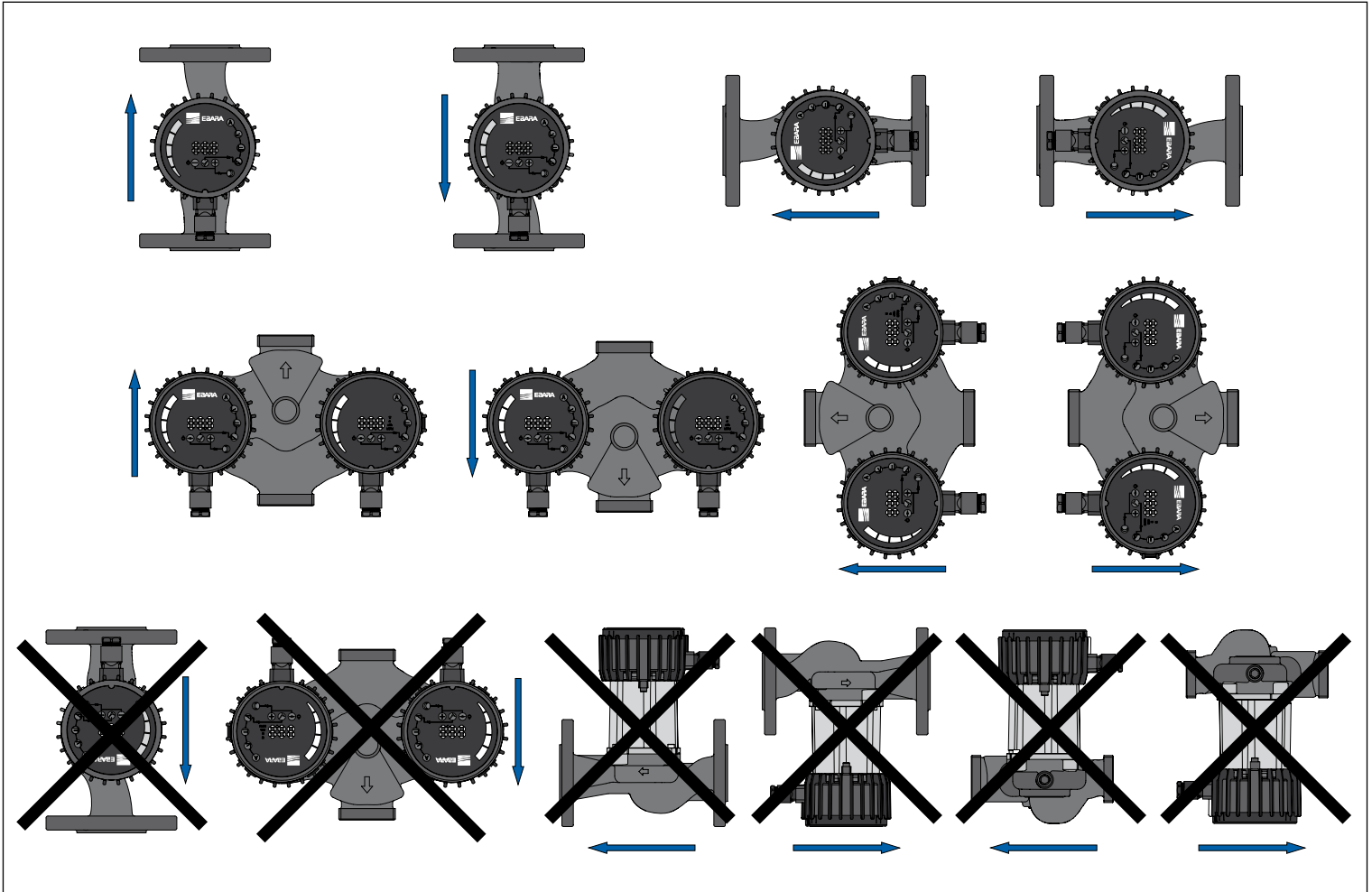

# Ego slim

## FLANGED CIRCULATORS

Ego (T) (C) slim 40, 50



High performance wet rotor circulation pump with flanged or threaded connection, motor with permanent magnets and built-in electronic controller.

### APPLICATIONS

Residential and industrial heating and air-conditioning systems.

### FEATURES

- Built-in frequency converter
- Multiple operating modes
- Numeric and graphical display for easy setup and visualisation of parameters
- Automatic venting function
- Built-in overload safety device
- High input torque (with consequent automatic release of the rotor)
- Optional version with built-in communication module (with Modbus, contact 0-10V etc.)

### PUMP TECHNICAL DATA

- Liquid temperature:  $-10 \div +110$  °C
- Room temperature:  $0 \div +40$  °C
- Relative air humidity:  $\leq 95\%$
- Allowed fluids: clean, non aggressive and not flammable, free of solid particles or fibres
- Maximum pressure: 10 bar
- Minimum suction pressure:
  - 0,05 bar to 50 °C
  - 0,8 bar to 80 °C
  - 1,4 bar to 110 °C
- Maximum amount of glycol: 20%\*
- Threaded inlets: G 1 1/2" – 2" (according to ISO 228)
- Flanged inlets: from DN 32 to DN 50
- Protection degree: IP44

### MOTOR TECHNICAL DATA

- Type: synchronous with permanent magnets
- Motor speed: variable
- Supply voltage: 1~230V
- Frequency: 50/60 Hz
- Insulation class: F

\* For greater amounts please check the final viscosity and the conditions of use.

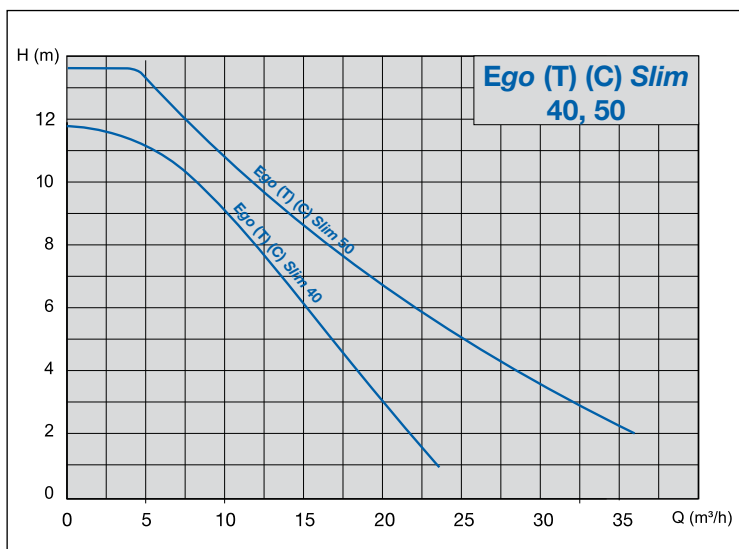

### IDENTIFICATION CODE

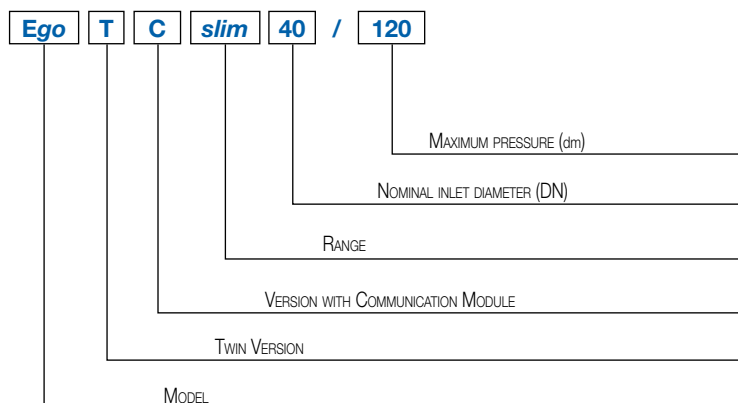

# Ego slim

## FLANGED CIRCULATORS

Ego (T) (C) slim 40, 50

### OPERATING MODES

The operating modes can be selected using the buttons located on the rear panel:

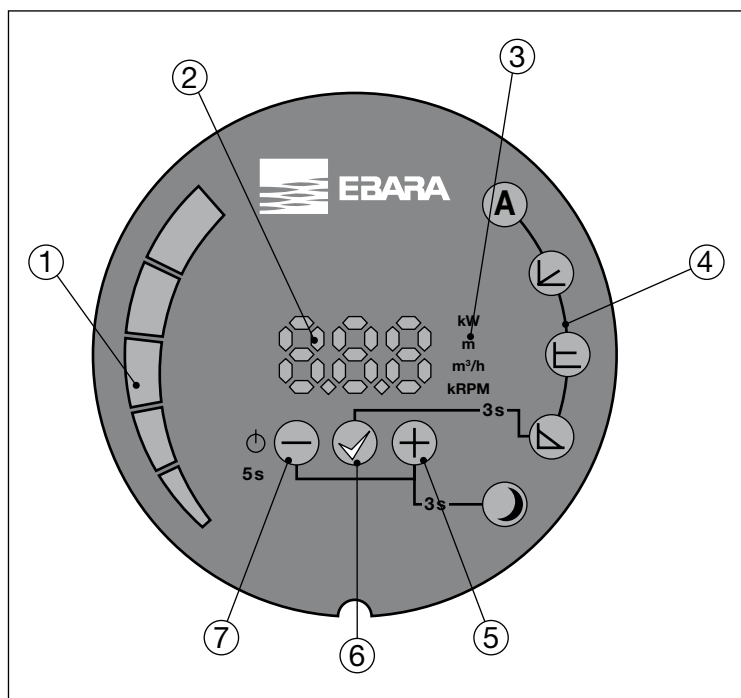

### KEY

- 1 Segment display
- 2 Numeric display
- 3 Display of selected parameter
- 4 Display of selected mode
- 5 Selection key
- 6 Confirmation key
- 7 Selection key

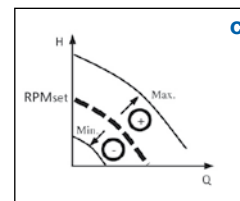
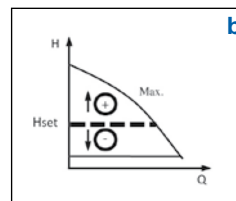
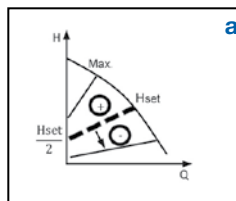

### AUTO mode (factory setting)

The circulator automatically adjusts the hydraulic performance depending on the actual requirements of the system, continuously measuring the optimal H/Q point. This operating mode is suitable for most applications and ensures high energy savings.



### Proportional pressure ( $\Delta P-v$ ) - fig. a

The circulator adjusts the pump head depending on the flow rate, varying the latter linearly from a maximum value ( $H_{set}$ ) to a minimum value (equal to  $H_{set}/2$ ). The pressure value ( $H_{set}$ ) is set via buttons  $\oplus$  and  $\ominus$  and is expressed in metres; the minimum value is automatically calculated by the circulator.



### Constant pressure ( $\Delta P-c$ ) - fig. b

The circulators maintains the pump head constant when the flow rates varies. The value of the pressure ( $H_{set}$ ) is set via buttons  $\oplus$  and  $\ominus$  and is expressed in metres.



### Constant speed - fig. c

The circulators operates according to a constant curve set via buttons  $\oplus$  and  $\ominus$  (by selecting the rotation speed in "rpm").



### Night mode

Night mode can be activated in combination with any of the operating modes listed above, and allows the circulator to operate at a minimum curve (therefore with very low consumption) when it detects a decrease in liquid temperature of 15-20 ° C. When temperature rises, it automatically returns to normal operating curve (according to the selected mode).

# Ego slim

## FLANGED CIRCULATORS

Ego (T) (C) slim 40, 50

### COMMUNICATION MODULE

Versions **Ego T C easy** are equipped with an additional communication module which can be accessed by opening the rear display panel. The communication module is also available as an optional accessory. It is compatible with all standard models Ego easy. The module enables running a wide range of applications remotely:

- Access via Ethernet
- Remote On/Off
- Analog control 0-10V
- Modbus RTU
- Alarm/state relay

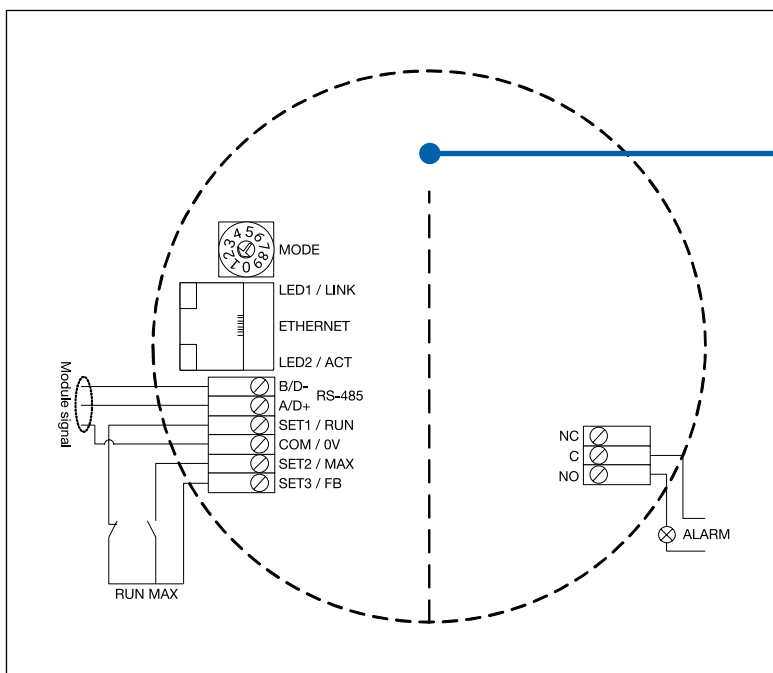
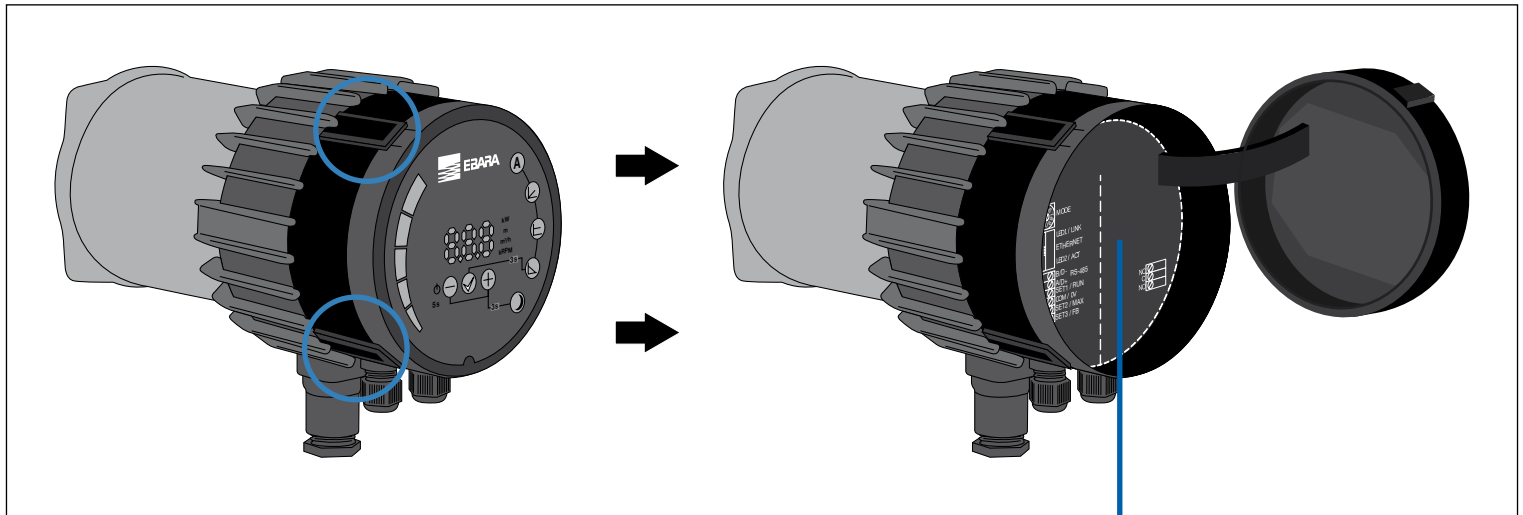





# Ego slim

## FLANGED CIRCULATORS

Ego (T) (C) slim 40, 50

### PERFORMANCE CURVES

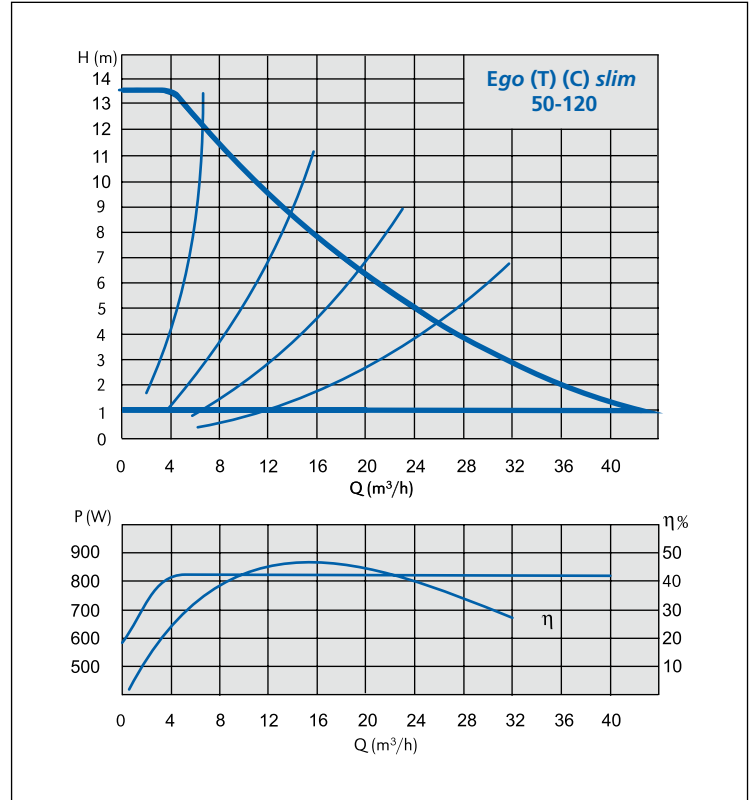
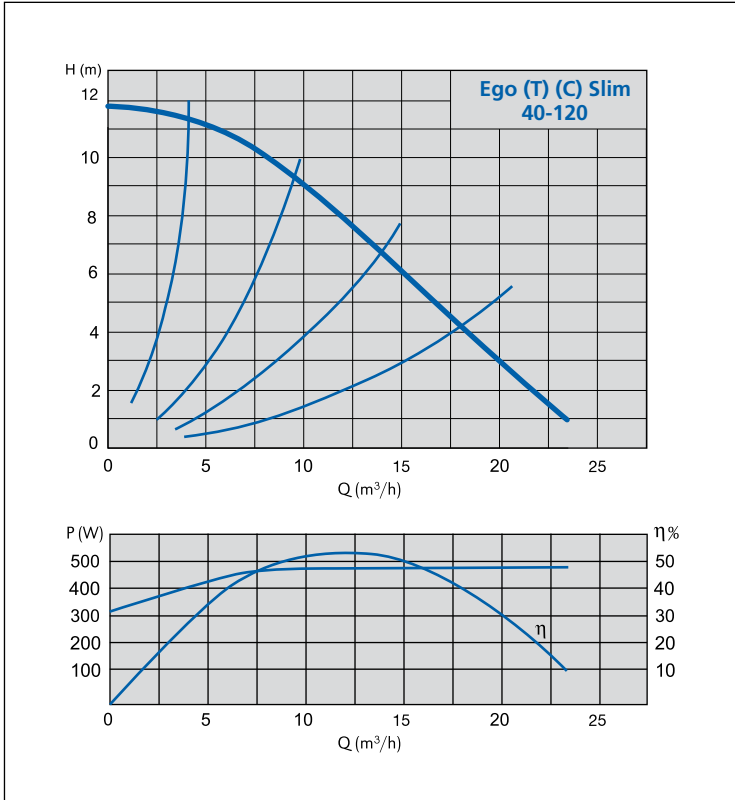

I contenuti della presente pubblicazione non devono essere considerati ingratificati. EBARA Pumps Europe S.p.A. si riserva il diritto di apportare senza preavviso le modifiche che riterrà più opportune.

# Ego slim

## FLANGED CIRCULATORS

Ego (T) (C) slim 40, 50

### SECTIONAL VIEW

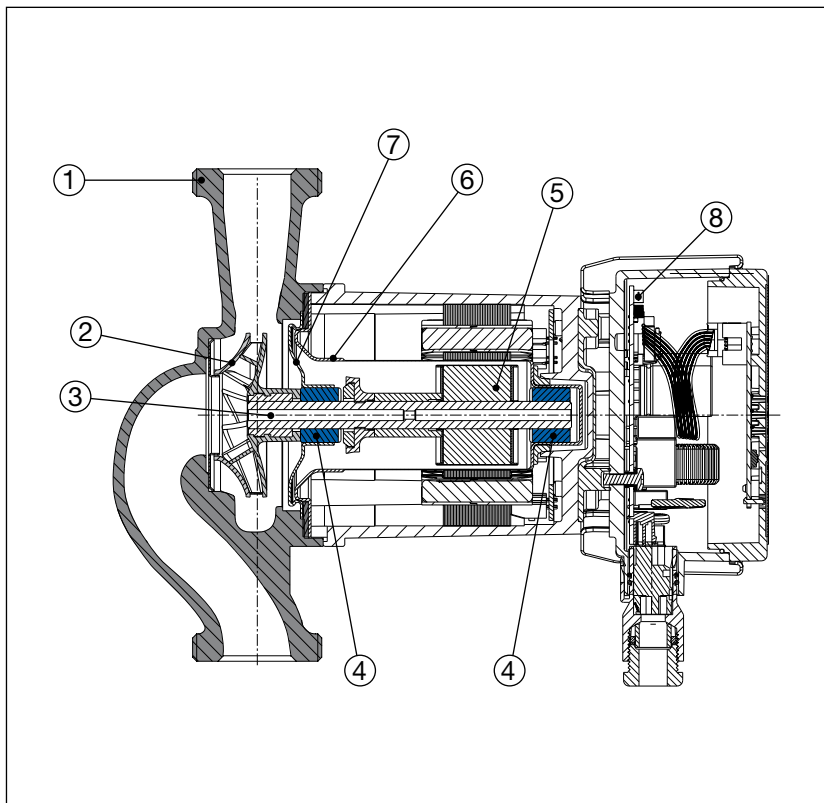

### MATERIAL TABLE

Ref.	Part	Material
1	Pump body	Cast iron with cataphoresis coating
2	Impeller	Technopolymer
3	Shaft	Stainless steel
4	Bearings	Graphite
5	Rotor	Coated in stainless steel
6	Rotor can	AISI 316 Stainless Steel
7	Bearing plate	AISI 316 Stainless Steel
8	Electronic board	-

### TECHNICAL FEATURES - single

Model	EEI (energy efficiency index)	Pipe connection	Power $P_1$ [W] $P_{max}$	Current consumption [A] $I_{min} - I_{max}$	Weight [kg]
Ego slim 40-120	$\leq 0,21$	DN 40	480	2,6 - 3,8	15,5
Ego slim 50-120	$\leq 0,21$	DN 50	800	-	20,1

### TECHNICAL FEATURES - twin

Model	EEI (energy efficiency index)	Pipe connection	Power $P_1$ [W] $P_{max}$	Current consumption [A] $I_{min} - I_{max}$	Weight [kg]
Ego TC slim 40-120	$\leq 0,21$	DN 40	480	2,6 - 3,8	29
Ego TC slim 50-120	$\leq 0,21$	DN 50	800	-	39,5

# Ego slim

## FLANGED CIRCULATORS

Ego (T) (C) slim 40, 50

### DIMENSIONS - singles

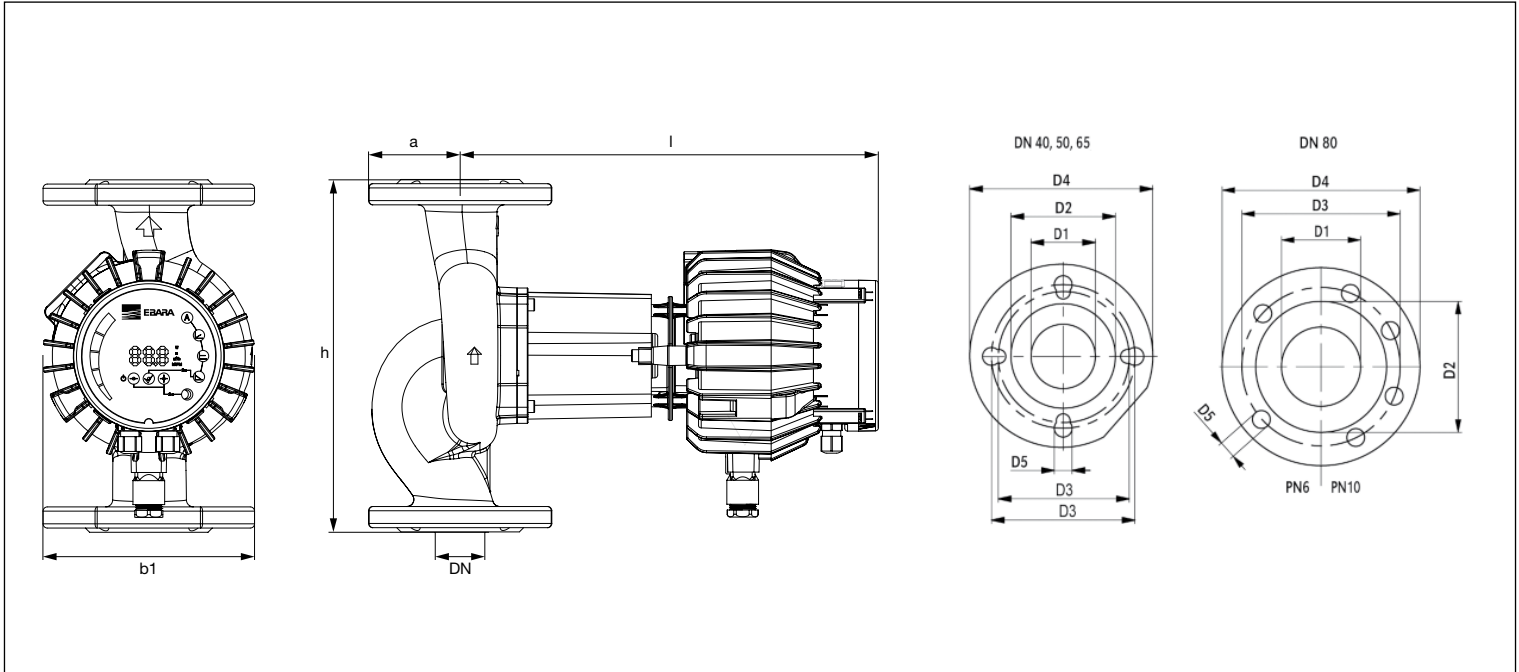

### DIMENSIONS TABLE - singles

Model	Dimensions [mm]										
	DN	b1	l	h	a	D1	D2	D3	D4	D5	n° fori
Ego slim 40-120	40	146	260 (292)*	250	65	40	80	110/110	150	14/19	4
Ego slim 50-120	50	146	260 (292)*	280	-	50	90	100/125	165	14/19	4

### DIMENSIONS - twin

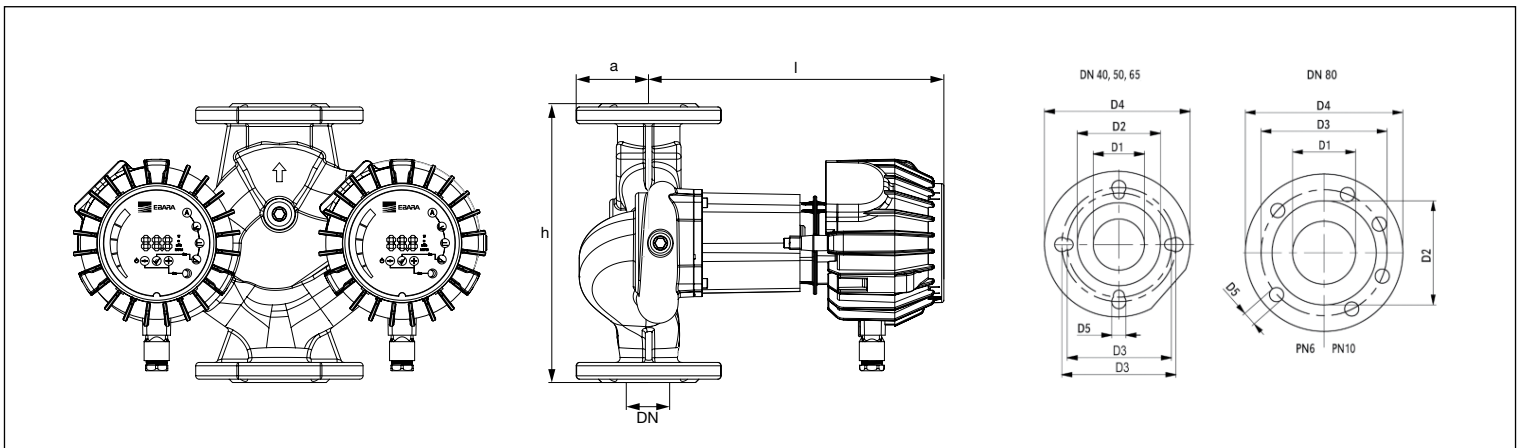

### DIMENSIONS - twin

Model	Dimensions [mm]										
	DN	l	h	a	D1	D2	D3	D4	D5	n° fori	
Ego TC slim 40-120	40	292	250	65	40	80	110/110	150	14/19	4	
Ego TC slim 50-120	50	292	280	-	50	90	100/125	165	14/19	4	

# Ego slim

## FLANGED CIRCULATORS

Ego (T) (C) slim 40, 50

### ASSEMBLY POSITION

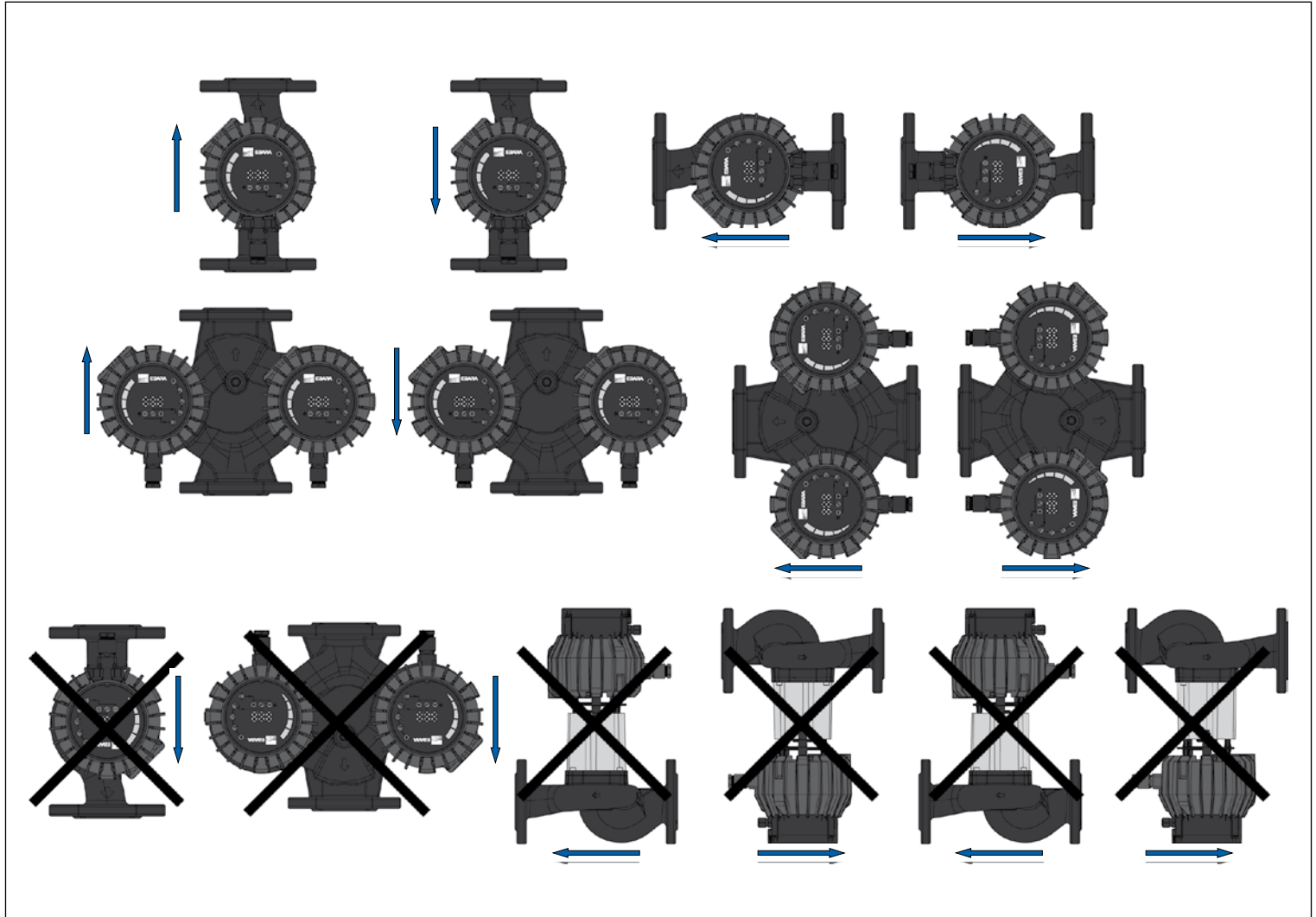

## FLANGED CIRCULATORS (12 e 18 m version)

Ego (T) C (H) single and twin



High performance wet rotor circulation pump with flanged connection, motor with permanent magnets and built-in electronic controller.

### APPLICATIONS

Residential and industrial heating and air-conditioning systems.

### FEATURES

- Built-in frequency converter
- Multiple operating modes
- Numeric and graphical display for easy setup and visualisation of parameters
- Automatic venting function
- Built-in overload safety device
- High input torque (with consequent automatic release of the rotor)
- Ethernet connection, digital inputs and relays included (standard)
- Optional version with built-in communication module (with Modbus, contact 0-10V etc.)

### PUMP TECHNICAL DATA

- Liquid temperature:  $-10 \div +110$  °C
- Room temperature:  $0 \div +40$  °C
- Relative air humidity:  $\leq 95\%$
- Allowed fluids: clean, non aggressive and not flammable, free of solid particles or fibres
- Maximum pressure: 10 bar
- Minimum suction pressure:
  - 0,3 bar to 50 °C
  - 1,1 bar to 80 °C
  - 1,6 bar to 110 °C
- Maximum amount of glycol: 20%\*
- Flanged inlets: from DN 40 to DN 100
- Protection degree: IP44

### MOTOR TECHNICAL DATA

- Type: synchronous with permanent magnets
- Motor speed: variable
- Supply voltage: 1~230V
- Frequency: 50/60 Hz
- Insulation class: F

\* For greater amounts please check the final viscosity and the conditions of use.

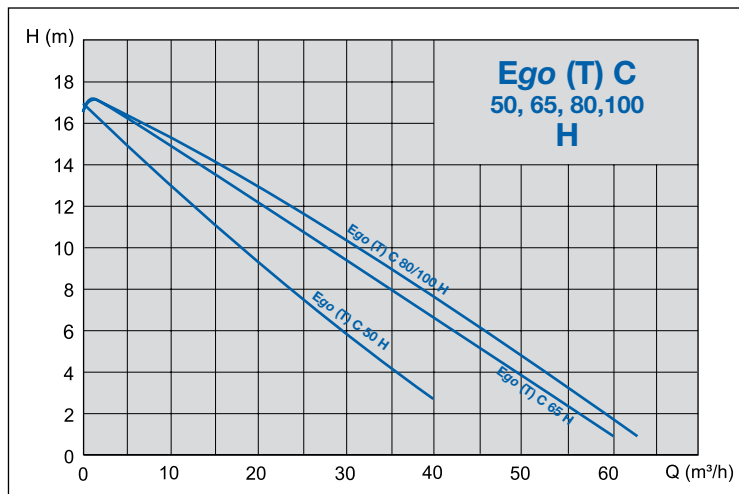
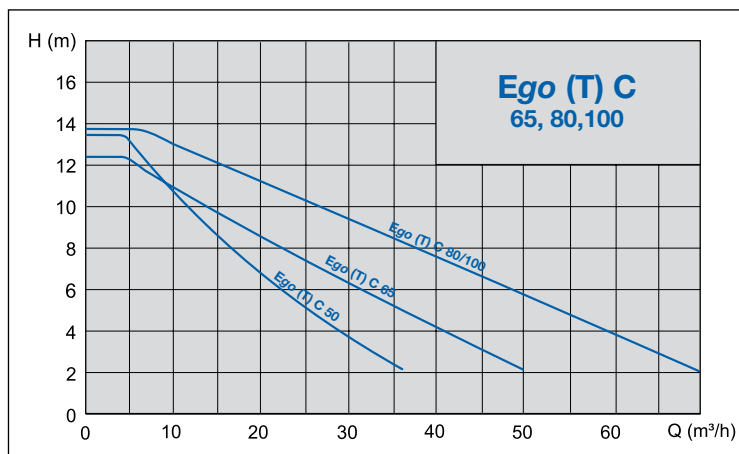

### IDENTIFICATION CODE

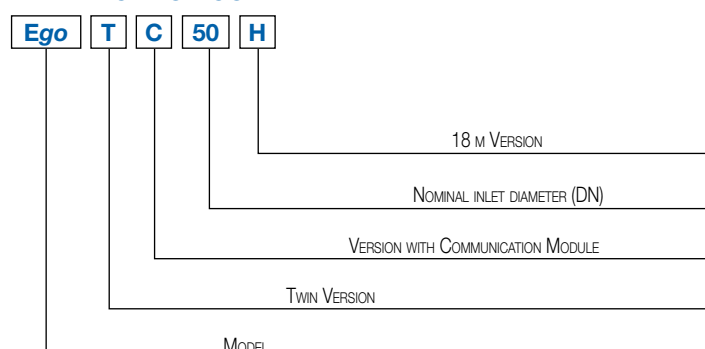

## FLANGED CIRCULATORS (12 e 18 m version)

Ego (T) C (H) single and twin

### OPERATING MODES

The operating modes can be selected using the buttons located on the rear panel:

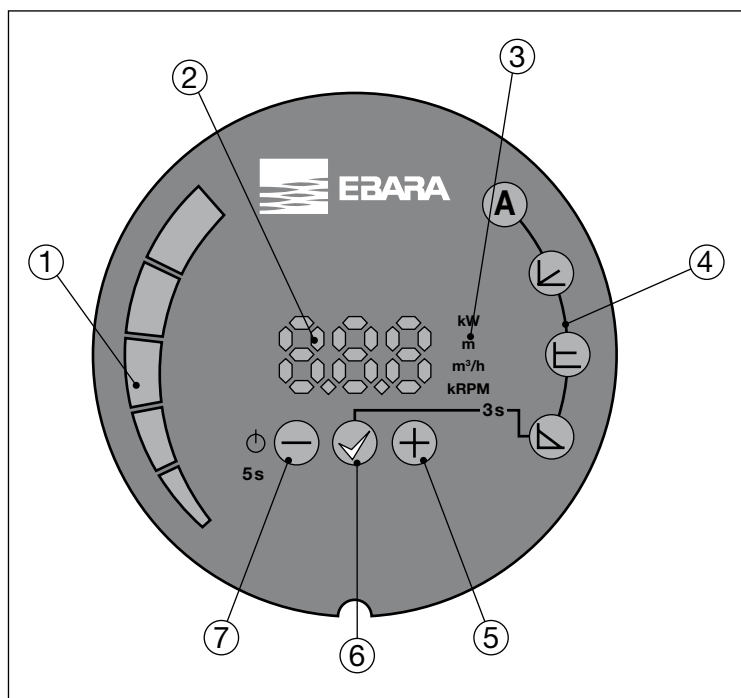

### KEY

- 1 Segment display
- 2 Numeric display
- 3 Display of selected parameter
- 4 Display of selected mode
- 5 Selection key
- 6 Confirmation key
- 7 Selection key

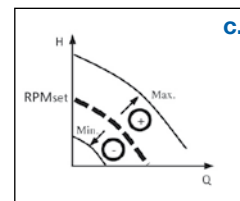
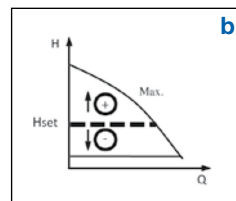
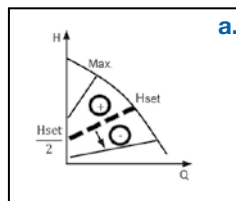

- A AUTO mode (factory setting)**  
The circulator automatically adjusts the hydraulic performance depending on the actual requirements of the system, continuously measuring the optimal H/Q point. This operating mode is suitable for most applications and ensures high energy savings.
- Proportional pressure (ΔP-v) - fig. a**  
The circulator adjusts the pump head depending on the flow rate, varying the latter linearly from a maximum value (Hset) to a minimum value (equal to  $H_{set}/2$ ). The pressure value (Hset) is set via buttons ⊕ and ⊖ and is expressed in metres; the minimum value is automatically calculated by the circulator.
- Constant pressure (ΔP-c) - fig. b**  
The circulator maintains the pump head constant when the flow rates varies. The value of the pressure (Hset) is set via buttons ⊕ and ⊖ and is expressed in metres.
- Constant speed - fig. c**  
The circulator operates according to a constant curve set via buttons ⊕ and ⊖ (by selecting the rotation speed in "rpm").

### REMOTE CONTROL

#### Standard configuration

The standard configuration of circulators Ego (T) provides:

- Ethernet connection for control via PC
- Digital inputs
- Output relay
- Analog control 0-10V
- Modbus RTU

## FLANGED CIRCULATORS (12 e 18 m version)

Ego (T) C (H) single and twin

### PERFORMANCE CURVES

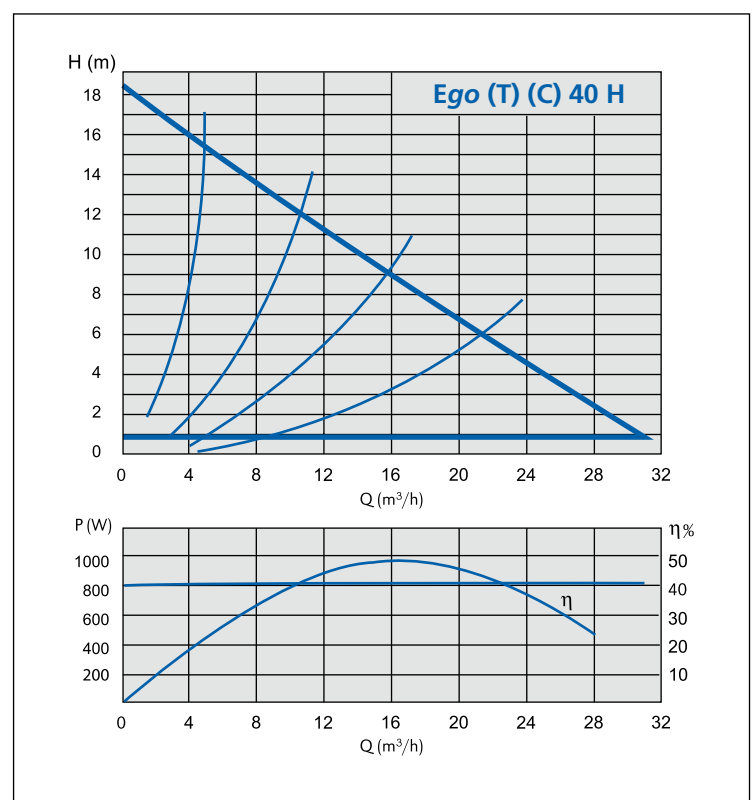
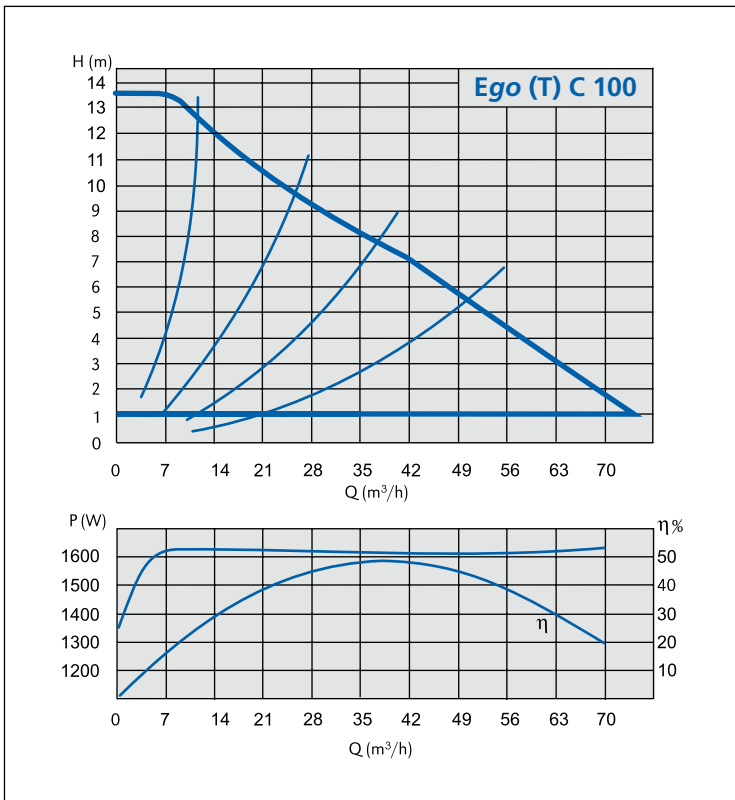
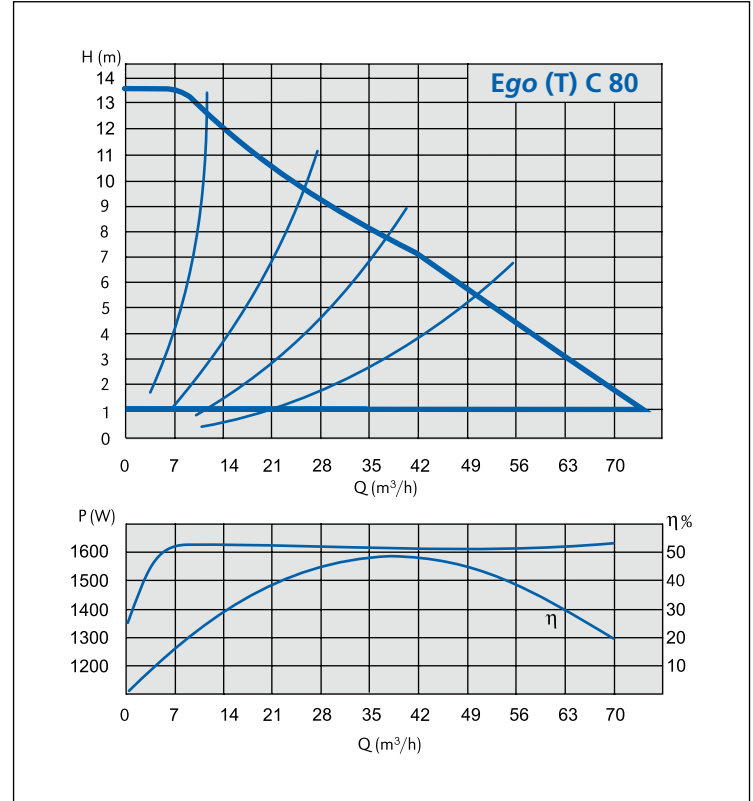
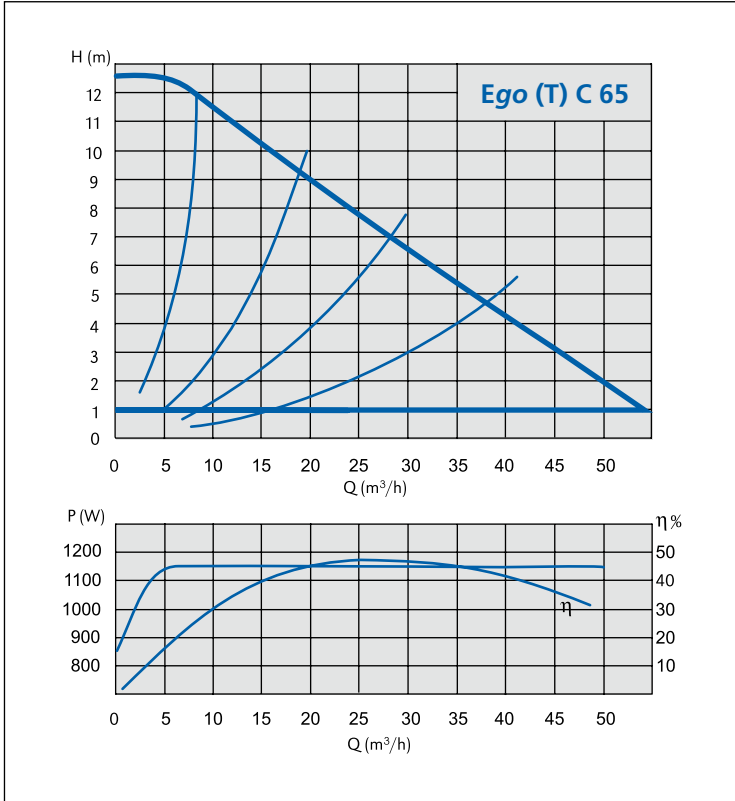

I contenuti della presente pubblicazione non devono essere considerati ingaranti. EBARA Pump Europe S.p.A. si riserva il diritto di apportare senza preavviso le modifiche che riterrà più opportune.

## FLANGED CIRCULATORS (12 e 18 m version)

Ego (T) C (H) single and twin

### PERFORMANCE CURVES

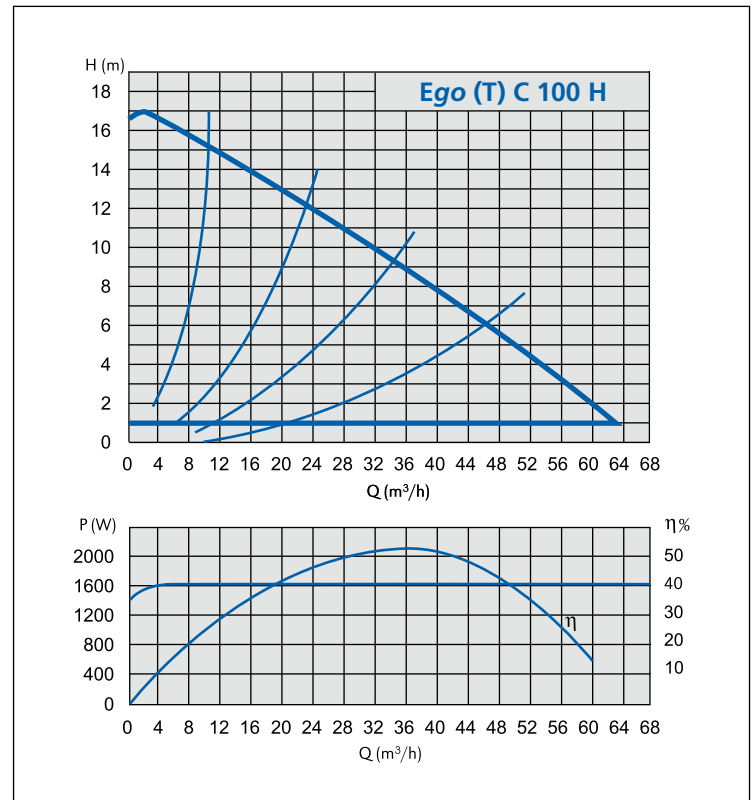
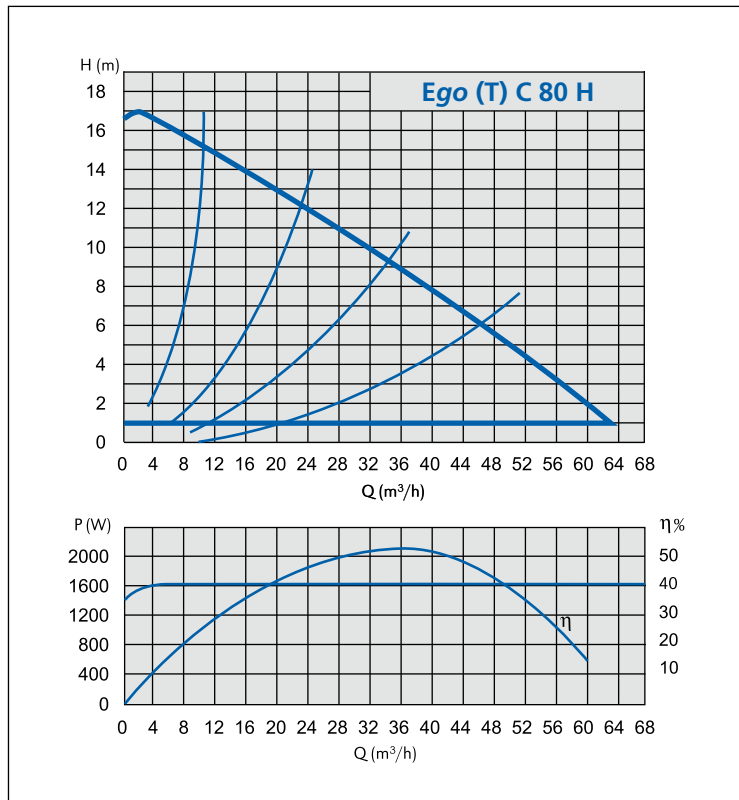
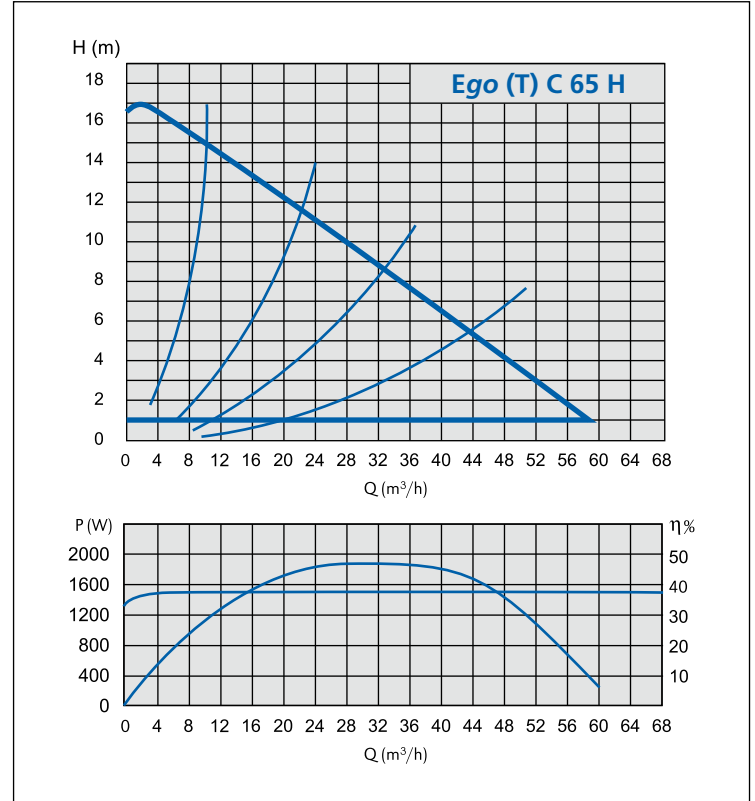
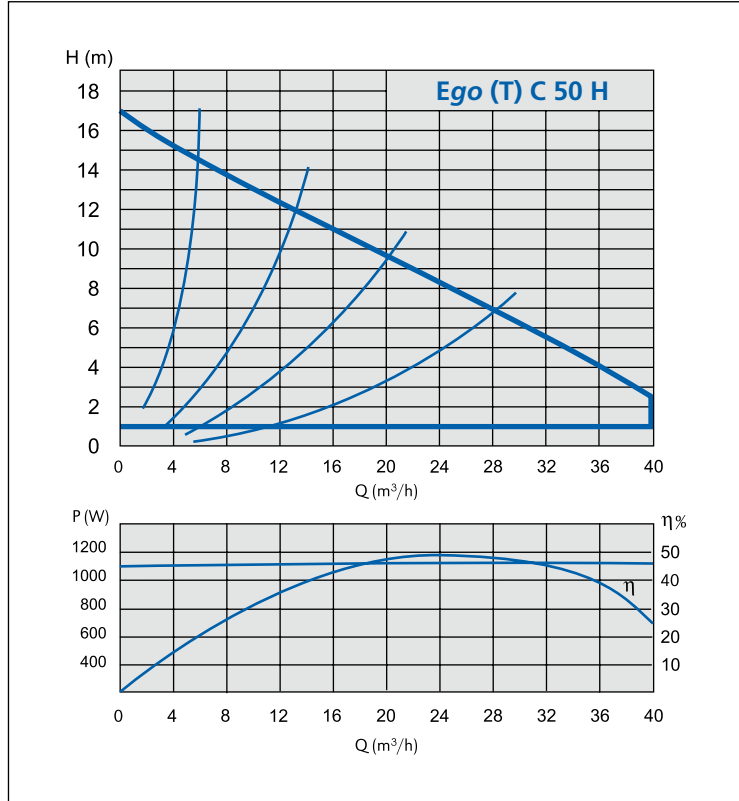



## FLANGED CIRCULATORS (12 e 18 m version)

Ego (T) C (H) single and twin

### SECTIONAL VIEW

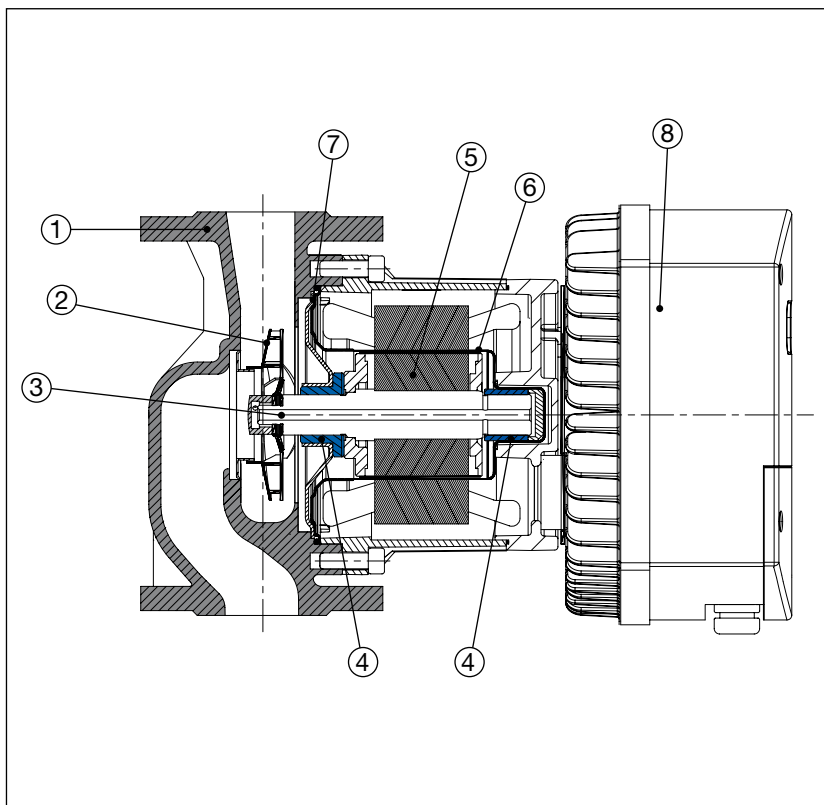

### MATERIAL TABLE

Ref.	Part	Material
1	Pump body	Cast iron with cataphoresis coated
2	Impeller	Stainless steel
3	Shaft	Stainless steel
4	Bearings	Graphite
5	Rotor	Coated in stainless steel
6	Rotor can	AISI 316 Stainless Steel
7	Bearing plate	AISI 316 Stainless Steel
8	Electronic board	-

### TECHNICAL FEATURES - single

Model	EEI (energy efficiency index)	Pipe connection	Power P <sub>1</sub> [W] P <sub>max</sub>	Current consumption [A] I <sub>min</sub> - I <sub>max</sub>	Weight [kg]
Ego C 40 H	≤ 0,23	DN40	500	2,2	24,3
Ego C 50 H	≤ 0,23	DN50	1100	4,8	30,0
Ego C 65	≤ 0,23	DN65	1100	4,8	36,0
Ego C 65 H	≤ 0,23	DN65	1500	6,7	39,0
Ego C 80	≤ 0,22	DN80	1600	6,9	42,0
Ego C 80 H	≤ 0,23	DN80	1600	7,3	41,0
Ego C 100	≤ 0,22	DN100	1600	6,9	46,0
Ego C 100 H	≤ 0,23	DN100	1600	7,2	45,0

### TECHNICAL FEATURES - twin

Model	EEI (energy efficiency index)	Pipe connection	Power P <sub>1</sub> [W] P <sub>max</sub>	Current consumption [A] I <sub>min</sub> - I <sub>max</sub>	Weight [kg]
Ego TC 40 H	≤ 0,23	DN40	500	2,2	47,0
Ego TC 50 H	≤ 0,23	DN50	1100	4,8	60,0
Ego TC 65	≤ 0,22	DN65	1100	4,8	66,0
Ego TC 65 H	≤ 0,23	DN65	1500	6,7	74,0
Ego TC 80	≤ 0,22	DN80	1600	6,9	77,0
Ego TC 80 H	≤ 0,23	DN80	1600	7,3	77,0

## FLANGED CIRCULATORS (12 e 18 m version)

Ego (T) C (H) single and twin

### DIMENSIONS - singles

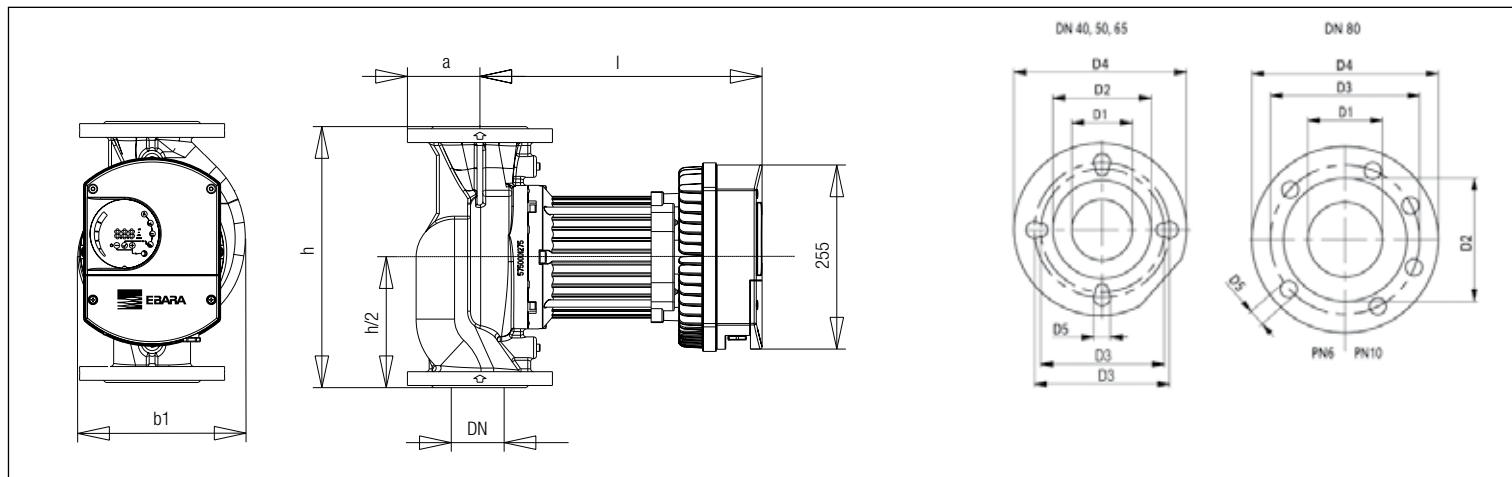

### DIMENSIONS TABLE - singles

Model	DN	b1	b4	l	h	Dimensions [mm]		D1	D2	D3	D4	D5	n° fori
						h1	a						
Ego C 40 H	40	198	-	355	250	-	65	40	80	100/110	150	14/19	4
Ego C 50 H	50	200	-	355	280	-	70	50	90	100/125	165	14/19	4
Ego C 65	65	222	-	369	340	-	80	65	110	130/145	185	14/19	4
Ego C 65 H	65	222	-	403	340	-	80	65	110	130/145	185	14/19	4
Ego C 80	80	230	-	403	360	-	100	80	128	160	200	19	8
Ego C 80 H	80	230	-	403	360	-	100	80	128	160	200	19	8
Ego C 100	100	230	-	403	360	-	110	100	-	180	220	19	8
Ego C 100 H	100	230	-	403	360	-	110	100	140	180	220	19	8

### DIMENSIONS - twin

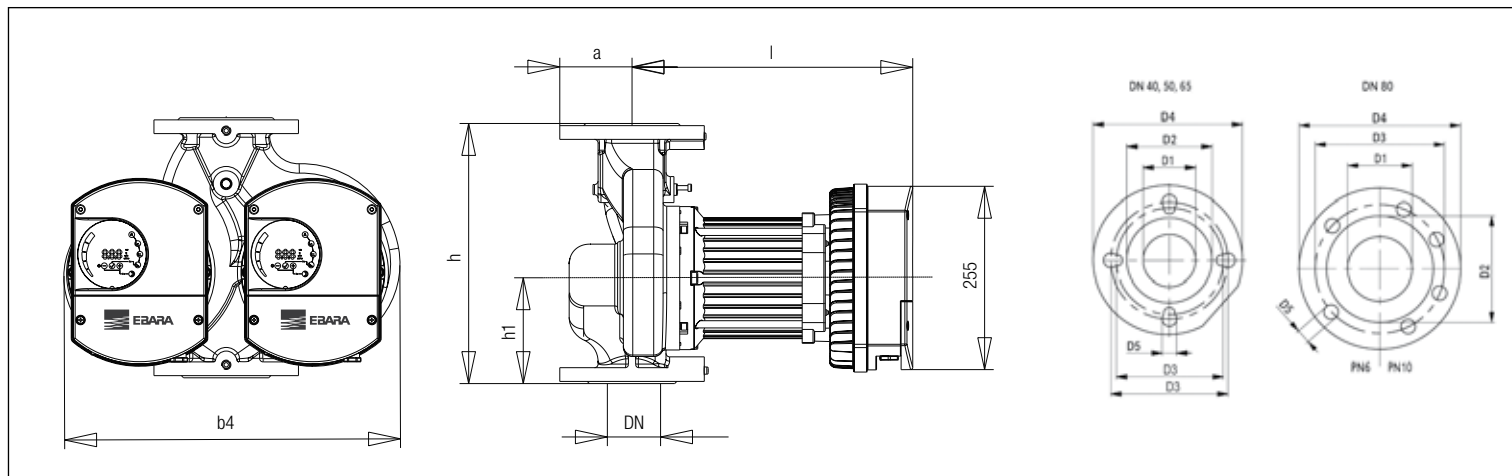

### DIMENSIONS TABLE - twin

Model	DN	b1	b4	l	h	Dimensions [mm]		D1	D2	D3	D4	D5	n° fori
						h1	a						
Ego TC 40 H	40	-	403	355	250	110	65	40	80	100/110	150	14/19	4
Ego TC 50 H	50	-	403	355	280	121	70	50	90	100/125	165	14/19	4
Ego TC 65	65	-	452	369	340	141	80	65	110	130/145	185	14/19	4
Ego TC 65 H	65	-	452	403	340	141	80	65	110	130/145	185	14/19	4
Ego TC 80	80	-	462	403	360	146	100	80	128	160	200	19	8
Ego TC 80 H	80	-	462	403	360	146	100	80	128	160	200	19	8

# Ego

## FLANGED CIRCULATORS (12 e 18 m version)

Ego (T) C (H) single and twin

### ASSEMBLY POSITION



# Ego B

## THREADED/FLANGED CIRCULATORS

Ego B - Ego B easy



Ego B threaded



Ego B easy



Ego B flanged

High performance wet rotor circulation pump suitable for sanitary plants with threaded or flanged connection. Ego B having bronze pump body and a permanent magnet motor, suitable for sanitary plants.

### IMPIEGHI

- Small sanitary plants
- Medium and big sanitary systems

### FEATURES

- Built-in frequency converter
- Numeric and graphical display for easy setup and visualisation of parameters
- Automatic venting function
- Built-in overload safety device
- High input torque (with consequent automatic release of the rotor)
- Possibility of four regulation modes (automatic, constant speed, variable  $\Delta p$ , constant  $\Delta p$ ) and Night-time mode\*\*
- Funzionalità integrate come il controllo a distanza (tramite contatto ON/OFF) e la supervisione dello stato di funzionamento (tramite relay di uscita)\*\*

\* Only for Ego B easy and Ego B flanged models

\*\* By adding module C for Ego B easy models; already included for Ego B flanged

### DATI TECNICI POMPA

- Liquid temperature:  $+5^{\circ}\text{C} \div +65^{\circ}\text{C}$
- Room temperature:  $0 \div +40^{\circ}\text{C}$
- Relative air humidity:  $\leq 95\%$
- Allowed fluids: clean, not aggressive and not flammable, free of solid particles or fibres
- Maximum pressure: 10 bar
- Minimum suction pressure:
  - 0,05 bar to  $50^{\circ}\text{C}$
  - 0,8 bar to  $80^{\circ}\text{C}$
  - 1,4 bar to  $110^{\circ}\text{C}$
- Threaded inlets: G 1 1/2" (according to ISO 228)
- Flanged inlets: from DN 32 to DN 50
- Protection degree: IP44

### MOTOR TECHNICAL DATA

- Type: synchronous with permanent magnets
- Motor speed: variable
- Supply voltage: 1~230V
- Frequency: 50/60 Hz
- Insulation class: F

### IDENTIFICATION CODE

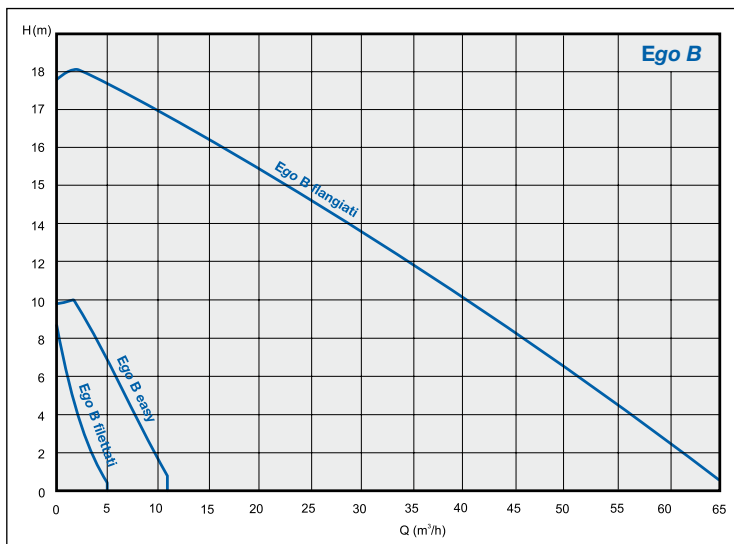
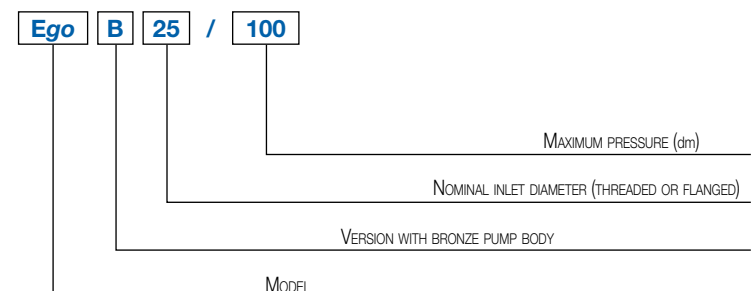

## THREADED/FLANGED CIRCULATORS

Ego B - Ego B easy

### OPERATING MODES

Two operating modes that can be selected using the LED button located on terminal box:

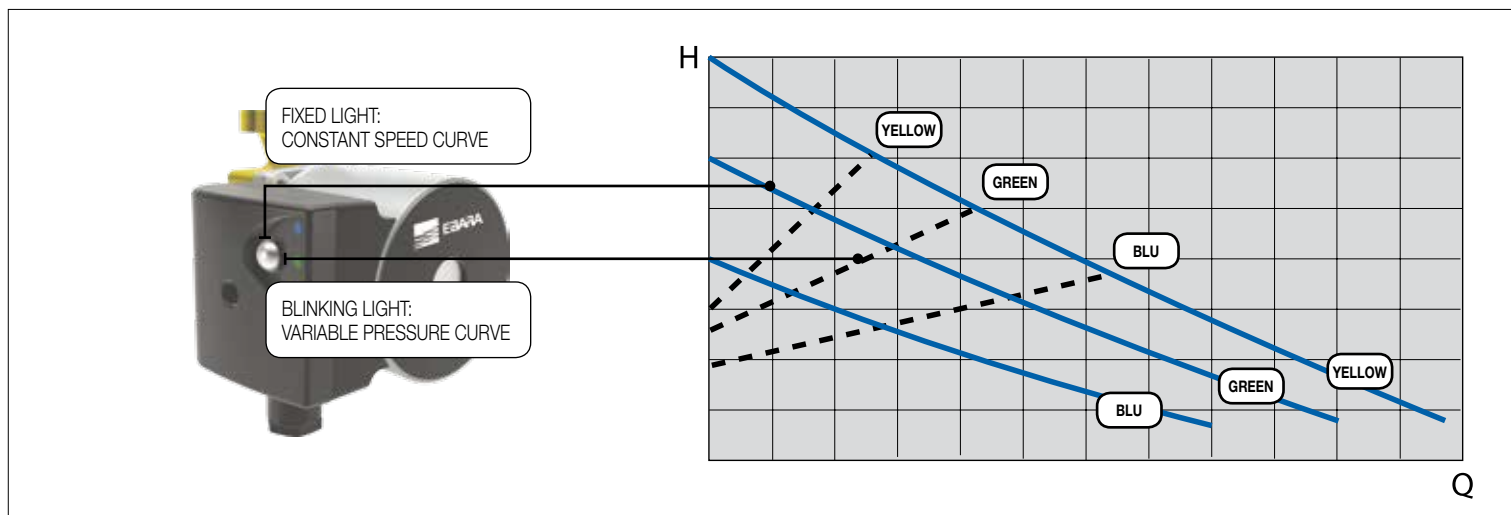

#### • $\Delta P-v$ Proportional pressure (factory setting)

The circulators of this range can work in variable pressure **mode on 3 preset curves**. When this operating mode is enabled **the LED button blinks**, with a frequency that varies according to instant flow rate. **The colour of the LED identifies the selected curve** (“blue” indicates the lowest curve, “green” the intermediate curve, while “yellow” indicates the highest curve); to switch from one curve to another just press the button briefly.

*From variable pressure modes (LED blinking) you can switch to constant speed mode (LED light steadily lit) keeping the LED button pressed for at least 5 seconds.*

#### • Constant speed

The circulators of this range can work at constant speed **on 3 preset curves**. In this case, the pump works as a usual pump without regulation and the power consumption remains constant. When this mode is active **the LED remains steadily lit**; in this case the colour of the LED **indicates the selected curve** (“blue” the lowest curve, “green” the intermediate curve, and “yellow” the highest curve). To switch from one curve to another, briefly press the button to return to variable pressure mode, select the desired curve (indicated by the colour of the LED) and then press and hold down the button.

## THREADED/FLANGED CIRCULATORS

Ego B - Ego B easy

### OPERATING MODES - Ego B easy/Ego B flanged

The operating modes can be selected using the buttons located on the rear panel:

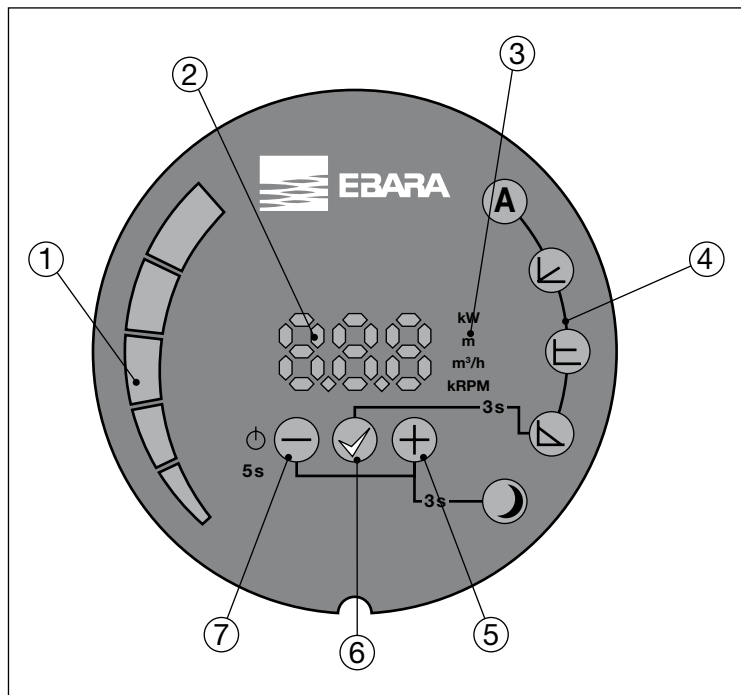

#### KEY

- 1 Segment display
- 2 Numeric display
- 3 Display of selected parameter
- 4 Display of selected mode
- 5 Selection key
- 6 Confirmation key
- 7 Selection key

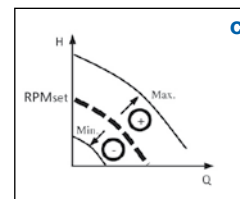
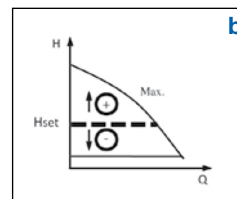
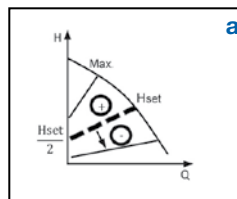

**A AUTO mode (factory setting)**  
The circulator automatically adjusts the hydraulic performance depending on the actual requirements of the system, continuously measuring the optimal H/Q point. This operating mode is suitable for most applications and ensures high energy savings.

**Proportional pressure ( $\Delta P-v$ ) - fig. a**  
The circulator adjusts the pump head depending on the flow rate, varying the latter linearly from a maximum value (Hset) to a minimum value (equal to  $H_{set}/2$ ). The pressure value (Hset) is set via buttons  $\oplus$  and  $\ominus$  and is expressed in metres; the minimum value is automatically calculated by the circulator.

**Constant pressure ( $\Delta P-c$ ) - fig. b**  
The circulators maintains the pump head constant when the flow rates varies. The value of the pressure (Hset) is set via buttons  $\oplus$  and  $\ominus$  and is expressed in metres.

**Constant speed - fig. c**  
The circulators operates according to a constant curve set via buttons  $\oplus$  and  $\ominus$  (by selecting the rotation speed in "rpm").

**Night mode**  
Night mode can be activated in combination with any of the operating modes listed above, and allows the circulator to operate at a minimum curve (therefore with very low consumption) when it detects a decrease in liquid temperature of 15-20 ° C. When temperature rises, it automatically returns to normal operating curve (according to the selected mode).



# Ego B

## THREADED/FLANGED CIRCULATORS

Ego B - Ego B easy

### PERFORMANCE CURVES - Ego B threaded

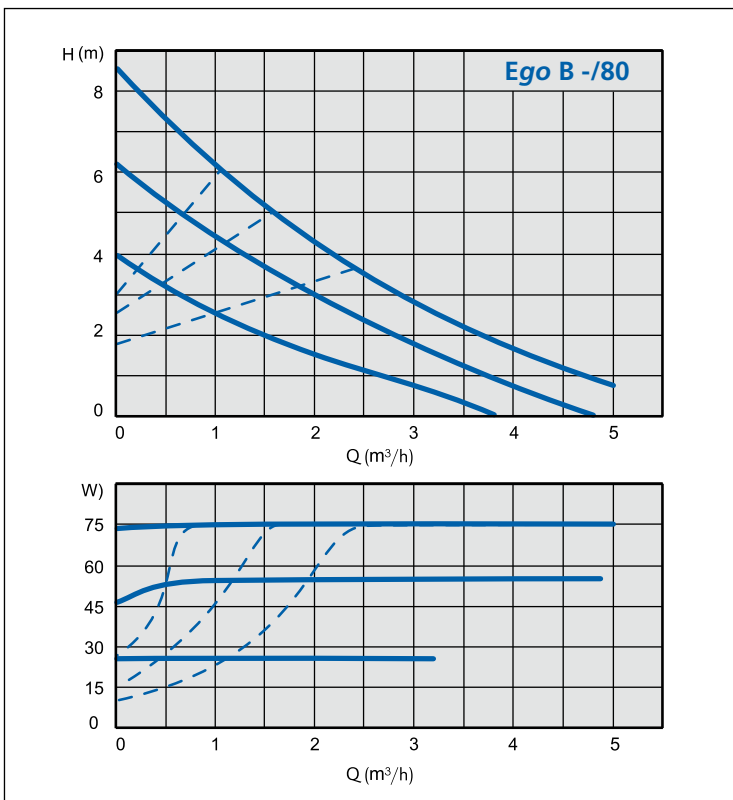
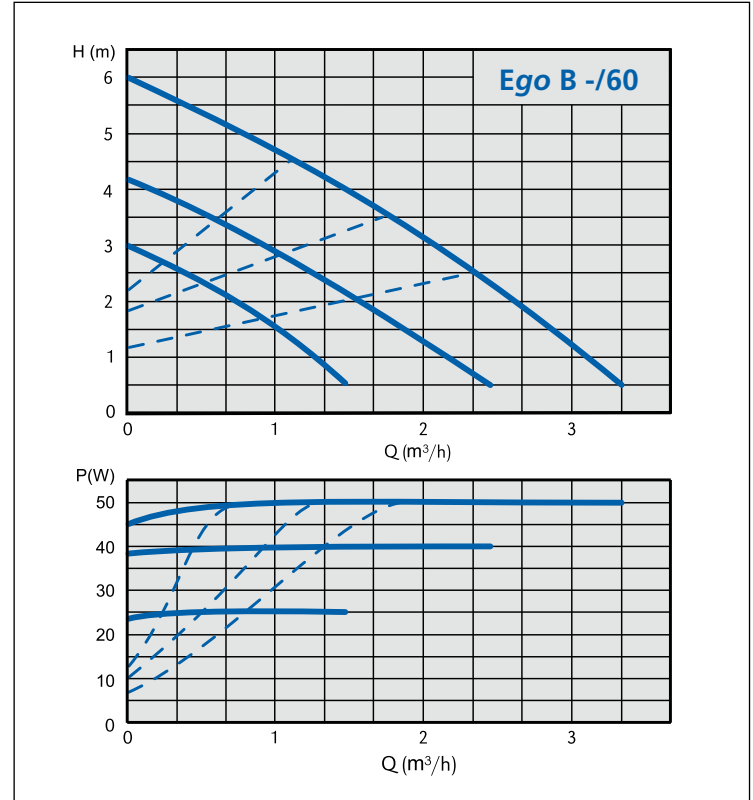
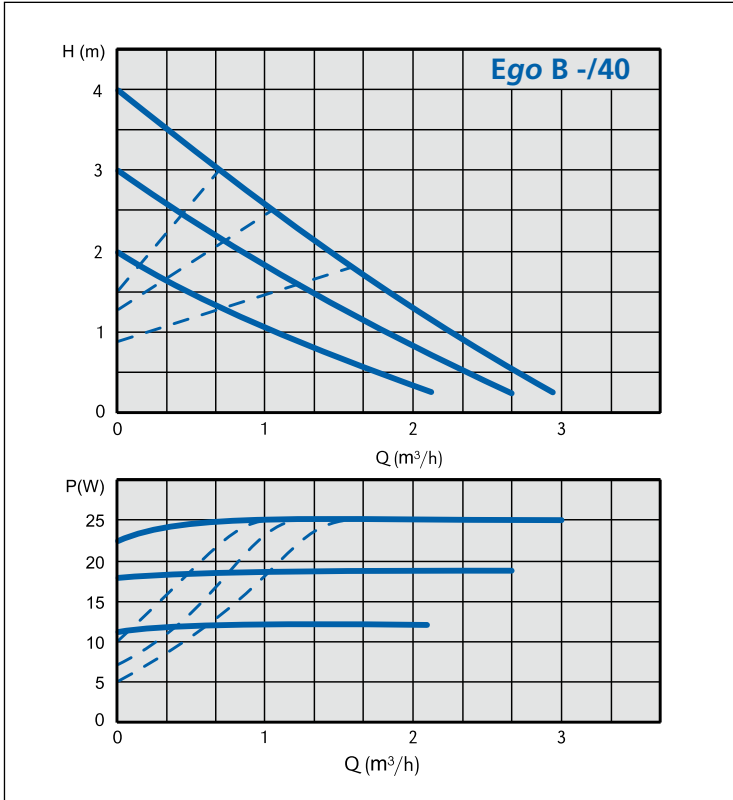

I contenuti della presente pubblicazione non devono essere considerati ingaranti. EBARA, Purgas, Ego e Ego S.p.A. si riserva il diritto di apportare senza preavviso le modifiche che riterrà più opportune.

## THREADED/FLANGED CIRCULATORS

Ego B - Ego B easy

### PERFORMANCE CURVES - Ego B easy

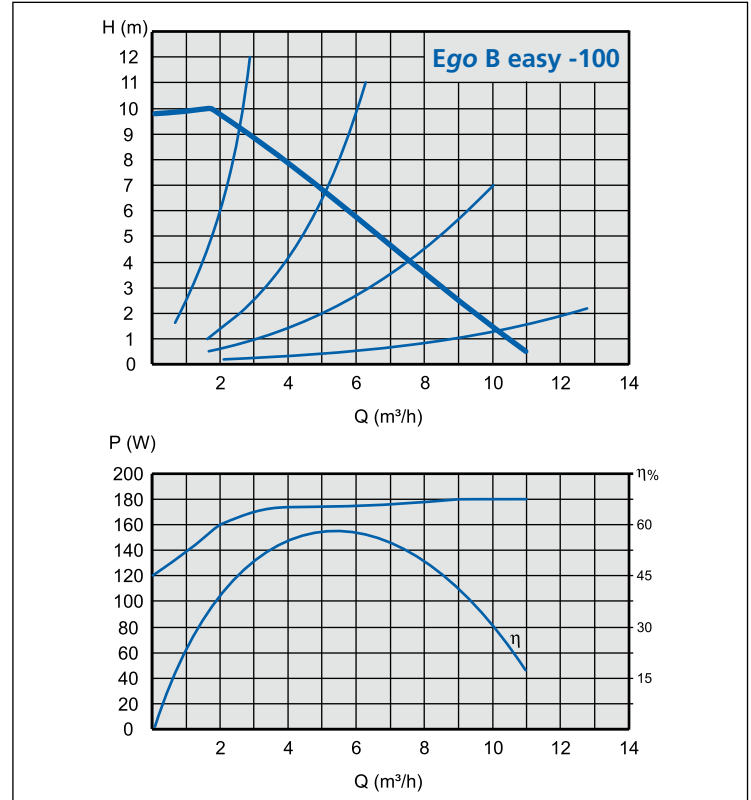
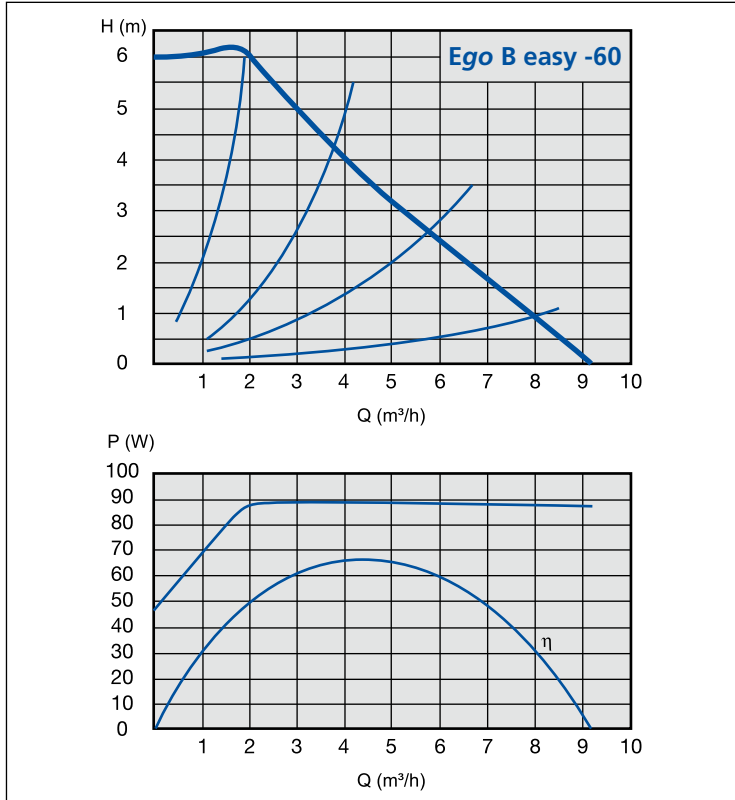





# Ego B

## THREADED/FLANGED CIRCULATORS

Ego B - Ego B easy

### PERFORMANCE CURVES - Ego B flanged

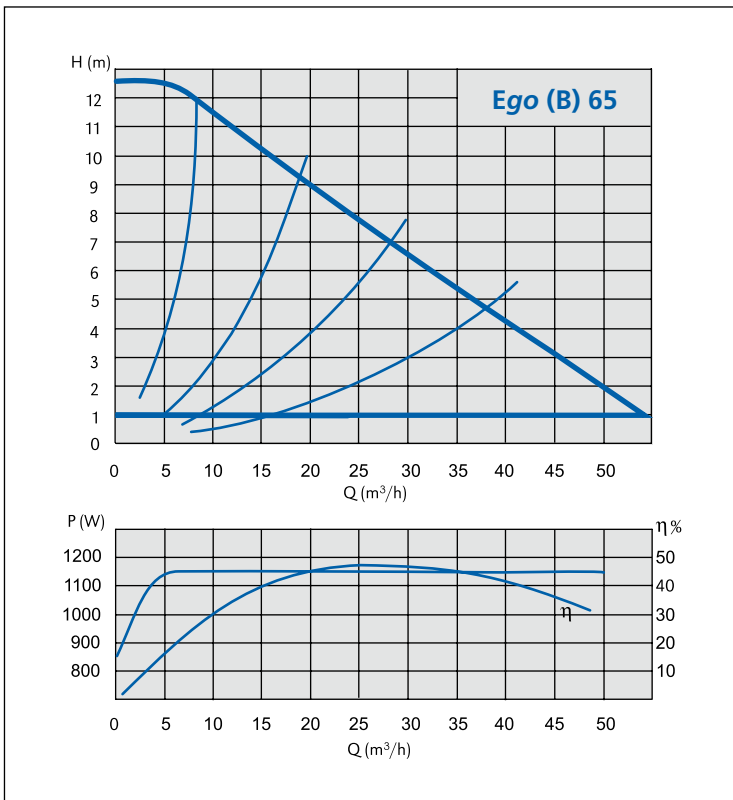
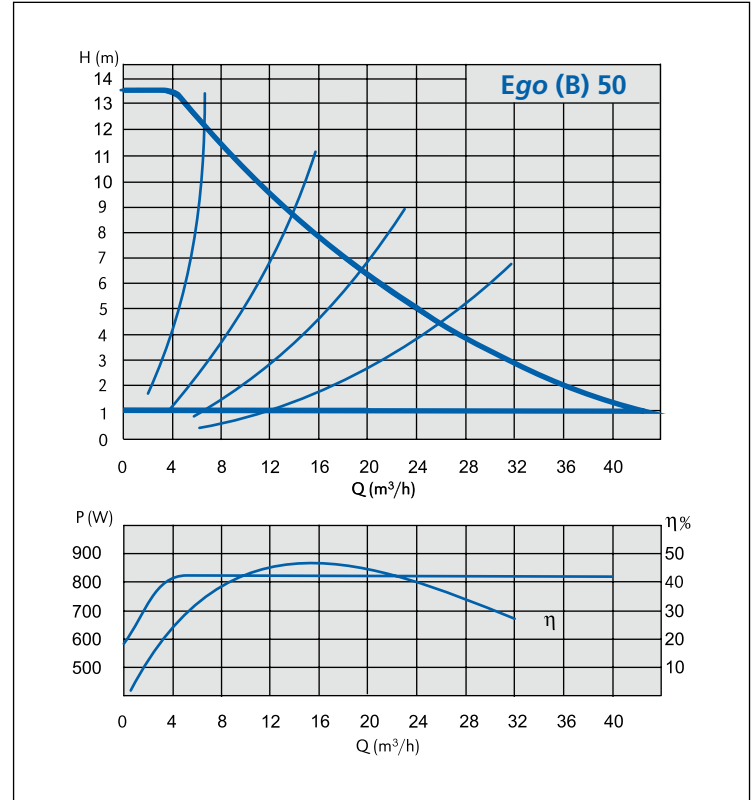
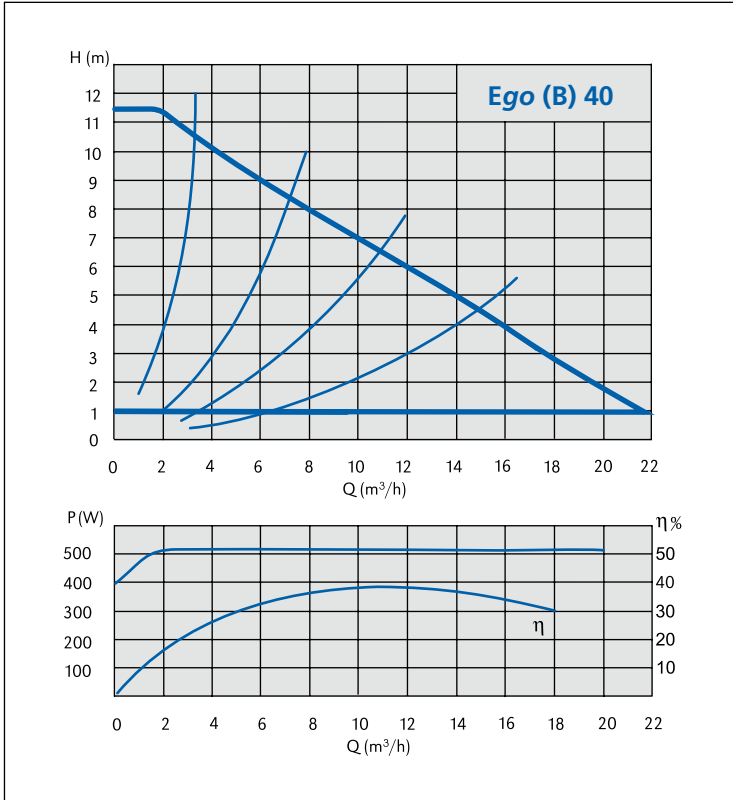

I contenuti della presente pubblicazione non devono essere considerati ingaranti. EBARA, Purgas, Ego e Ego S.p.A. si riservano il diritto di apportare senza preavviso le modifiche che riterrà più opportune.

# Ego B

## THREADED/FLANGED CIRCULATORS

Ego B - Ego B easy

**SECTIONAL VIEW - Ego B threaded**

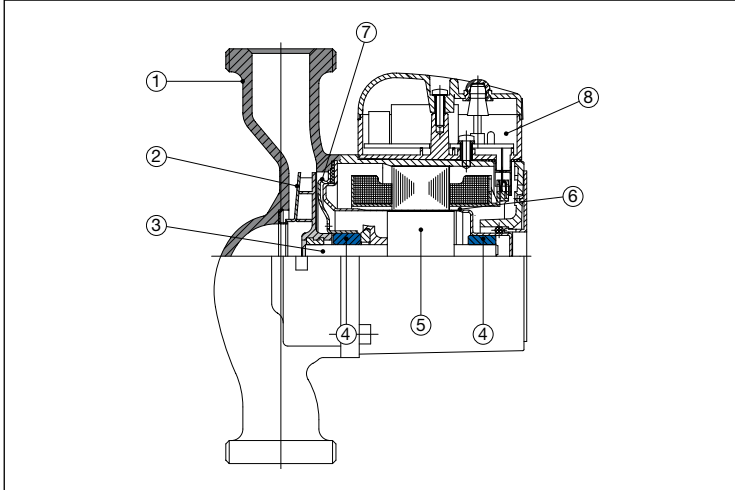

**MATERIAL TABLE**

Ref.	Part	Material
1	Pump body	Bronze
2	Impeller	Technopolymer
3	Shaft	Ceramic
4	Bearings	Ceramic
5	Rotor	Coated in stainless steel
6	Rotor can	AISI 316 Stainless Steel
7	Bearing plate	AISI 316 Stainless Steel
8	Electronic board	-

**SECTIONAL VIEW - Ego B easy**

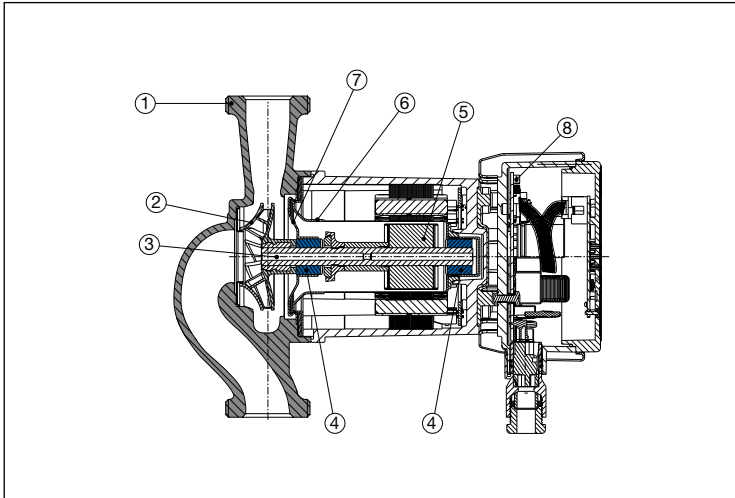

**MATERIAL TABLE**

Ref.	Part	Material
1	Pump body	Bronze
2	Impeller	Technopolymer
3	Shaft	Stainless steel
4	Bearings	Graphite
5	Rotor	Coated in stainless steel
6	Rotor can	AISI 316 Stainless Steel
7	Bearing plate	AISI 316 Stainless Steel
8	Electronic board	-

**SECTIONAL VIEW - Ego B flanged**

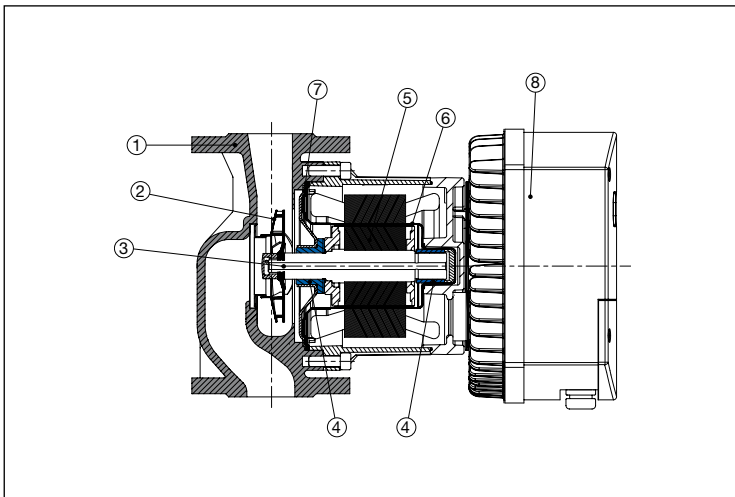

**MATERIAL TABLE**

Ref.	Part	Material
1	Pump body	Bronze
2	Impeller	Stainless steel
3	Shaft	Stainless steel
4	Bearings	Graphite
5	Rotor	Coated in stainless steel
6	Rotor can	AISI 316 Stainless Steel
7	Bearing plate	AISI 316 Stainless Steel
8	Electronic board	-

# Ego B

## THREADED/FLANGED CIRCULATORS

Ego B - Ego B easy

### TECHNICAL FEATURES - Ego B threaded

Model	Pipe connection	Inlet fitting	Power $P_1$ [W] $P_{max}$	Current consumption [A] $I_{min} - I_{max}$	Weight [kg]
Ego 25/40-130	G1½	Rp 1"	25	0,05 ÷ 0,2	2,1
Ego 25/60-130	G1½	Rp 1"	50	0,05 ÷ 0,4	2,1
Ego 25/80-130	G1½	Rp 1"	75	0,05 ÷ 0,6	2,1

### TECHNICAL FEATURES - Ego B easy

Model	Pipe connection	Inlet fitting	Power $P_1$ [W] $P_{max}$	Current consumption [A] $I_{min} - I_{max}$	Weight [kg]
Ego easy 25-80	G1½	Rp 1"	140	0,1 ÷ 1,15	4,0
Ego easy 32-80	G2"	Rp 1¼"	140	0,1 ÷ 1,15	4,1
Ego easy 25-100	G1½	Rp 1"	180	0,1 ÷ 1,5	4,0
Ego easy 32-100	G2"	Rp 1¼"	180	0,1 ÷ 1,5	4,1

### TECHNICAL FEATURES - Ego B flanged

Model	Pipe connection	Power $P_1$ [W] $P_{max}$	Current consumption [A] $I_{min} - I_{max}$	Weight [kg]
Ego B 40	DN40	500	2,2	24,3
Ego Ego B 50	DN50	1100	4,8	30,0
Ego B 65	DN65	1100	4,8	36,0

# Ego B

## THREADED/FLANGED CIRCULATORS

Ego B - Ego B easy

### DIMENSIONS - Ego B threaded

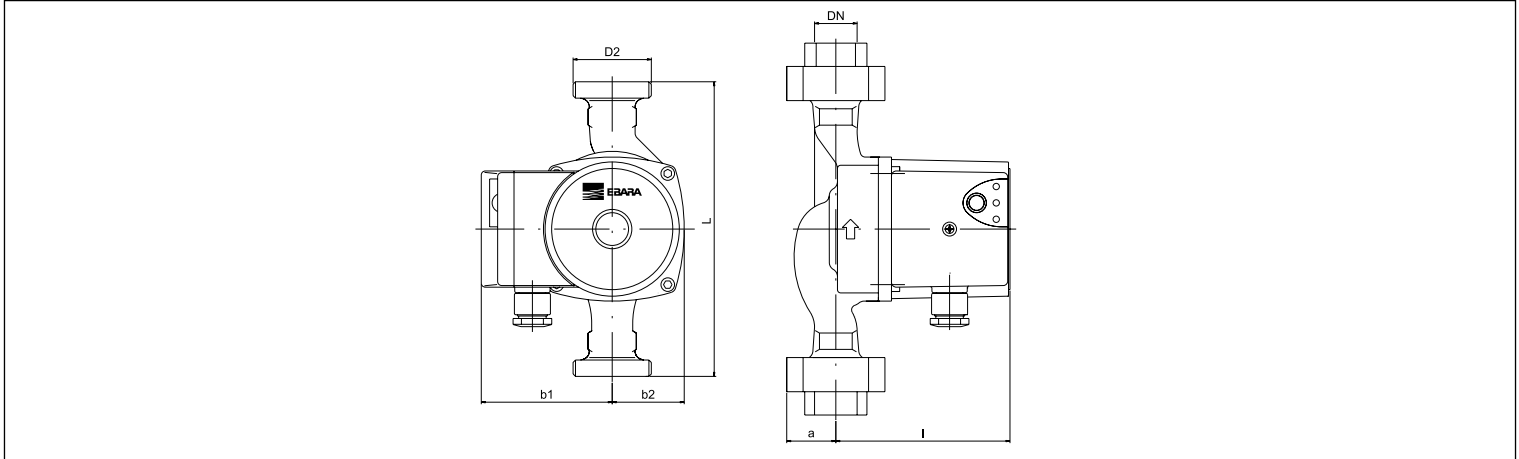

### DIMENSIONS TABLE- Ego B threaded

Model	Dimensions [mm]						
	L	DN	b1	b2	l	a	D2
Ego B 25/40-130	130	25	80	48	108	32	1"½
Ego B 25/60-130	130	25	80	48	108	32	1"½
Ego B 25/80-130	130	25	80	48	108	32	1"½

### DIMENSIONS - Ego B easy

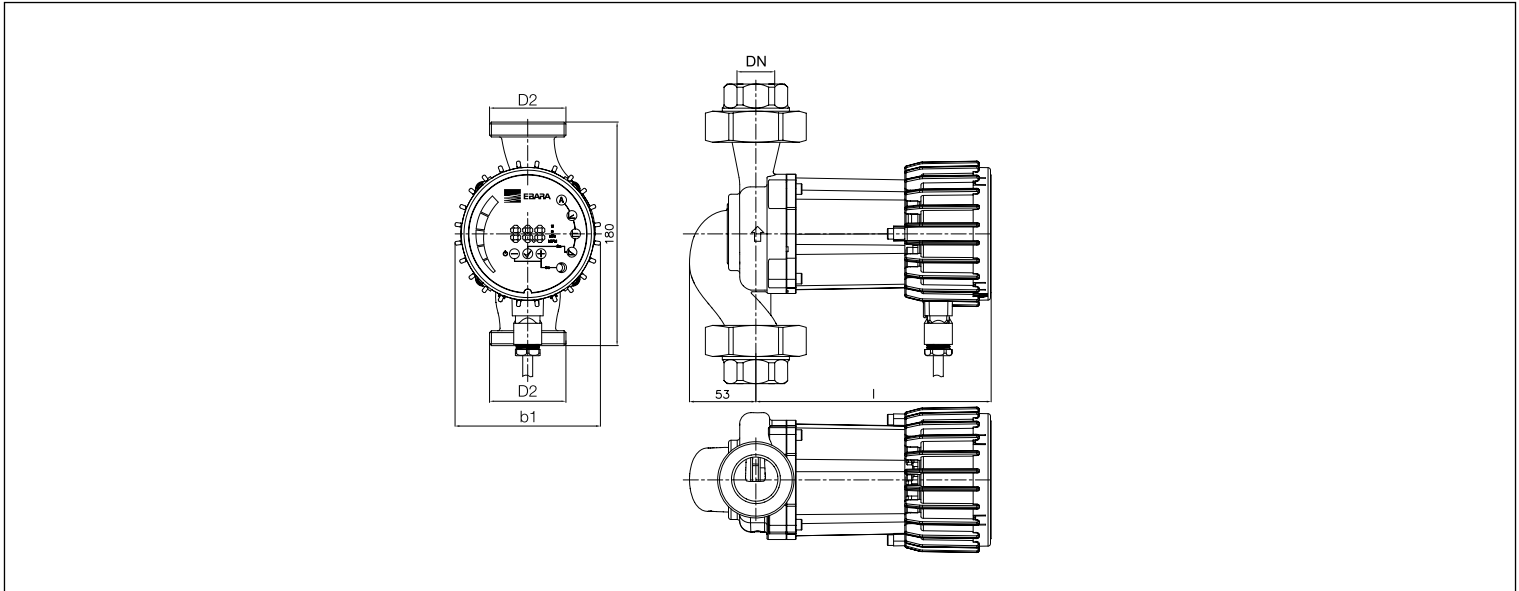

### DIMENSIONS TABLE - Ego B easy

Model	Dimensions [mm]										
	h	DN	b1	l	a	D1	D2	D3	D4	D5	n° fori
Ego easy 25-80	180	25	117	190 (222)*	-	-	1"½	-	-	-	-
Ego easy 32-80	180	32	117	190 (222)*	-	-	2"	-	-	-	-
Ego easy 25-100	180	25	117	190 (222)*	-	-	1"½	-	-	-	-
Ego easy 32-100	180	32	117	190 (222)*	-	-	2"	-	-	-	-

# Ego B

## THREADED/FLANGED CIRCULATORS

Ego B - Ego B easy

### DIMENSIONS - Ego B flanged

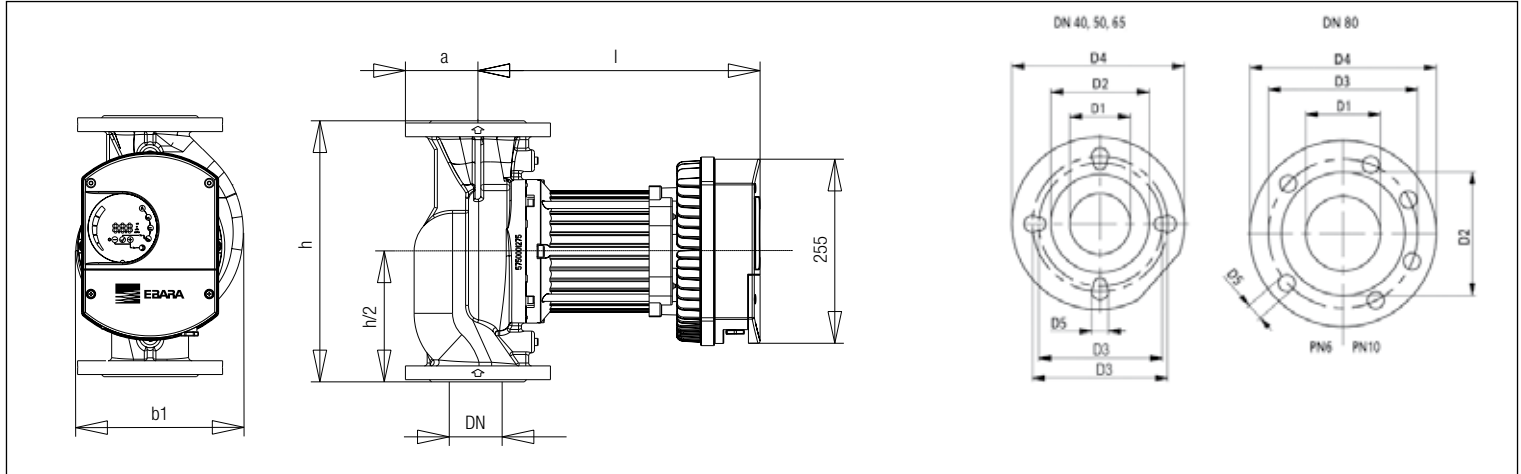

### DIMENSIONS TABLE- Ego B flanged

Model	DN	b1	b4	l	h	Dimensions [mm]		D1	D2	D3	D4	D5	n° fori
						h1	a						
Ego B 40	40	198	-	355	250	-	65	40	80	100/110	150	14/19	4
Ego B 50	50	200	-	355	280	-	70	50	90	100/125	165	14/19	4
Ego B 65	65	222	-	369	340	-	80	65	110	130/145	185	14/19	4

## THREADED CIRCULATORS COMPARISON WITH COMPETITORS

for small plants

### COMPARISON WITH COMPETITORS - THREADED CIRCULATORS

EBARA		DAB			GRUNDFOS				WILO		
Code	Model	Electronics		3 speed VA	Alpha2 (2L)	Electronics		3 speed Ups	Electronics		3 speed Star-RS
		Evosta	Evotron			Upe	Alpha + Alpha Pro		Yonos Pico Stratos Pico	Star-E	
1576000000	Ego 15/40-130	40-70/130 (1/2")	40/130 (1/2")	35 (55)/130 (1/2")	15-40	15-40 130	15-40 130	-	15/1-4-130	-	15/4-130
1576000001	Ego 25/40-130	40-70/130	40/130	35 (55)/130	25-40 130	25-40 130	25-40 130	25-40 130	25/1-4-130	25/1-3-130	-
1576000002	Ego 15/60-130	40-70/130 (1/2")	60/130 (1/2")	65/130 (1/2")	15-60	15-60 130	15-60 130	-	15/1-6-130	15/1-5	15/6-130
1576000003	Ego 25/60-130	40-70/130	60/130	65/130	25-60	25-60 130	25-60 130	-	25/1-6-130	25/1-5-130	25/4-130
1576000004	Ego 25/80-130	-	80/130	-	-	-	-	-	-	-	-
1576000005	Ego 25/40-180	40-70/180	40/180	35 (55)/180	25-40 180	25-40 180	25-40 180	25-40 180	25/1-4	25/1-3	25/2
1576000006	Ego 32/40-180	-	40/180 X	35 (55)/180 X	32-40	32-40 180	32-40 180	32-40 180	30/1-4	30/1-3	30/2
1576000007	Ego 25/60-180	40-70/180	60/180	65/180	25-60 180	25-60 180	25-60 180	25-60 180	25/1-6	25/1-5	25/4
1576000008	Ego 32/60-180	-	60/180 X	65/180 X	32-60	32-60 180	32-60 180	32-60 180	30/1-6	30/1-5	30/6
1576000009	Ego 25/80-180	-	80/180	-	-	25-80 180	-	25-80 180	-	-	-
1576000010	Ego 32/80-180	-	80/180 X	-	-	32-80 180	-	32-80 180	-	-	-

EBARA		LOWARA			CALPEDA			SALMSON		
Code	Model	Electronics		3 speed TLC	Electronics		3 speed NC3	Electronics		3 speed NYL/NXL
		EA(+), EV+	ECOCIRC		NC3	NCE EI		SiriuX Home	SiriuX Jr	
1576000000	Ego 15/40-130	15-4/130	15-4/130	15-2,5	15-40/130	-	15-40/130	40-15/130	3m-130	NYL 33-15
1576000001	Ego 25/40-130	25-4/130	25-4/130	25-4	25-40/130	-	25-40/130	-	-	NYL 33-25
1576000002	Ego 15/60-130	15-6/130	15-6/130	25-6	15/60-130	15-60/130	15-60/130	60-25/130	5m-130	NYL 53-15
1576000003	Ego 25/60-130	25-6/130	25-6/130	15-6	25-60/130	25-60/130	25-60/130	-	-	NYL 53-25
1576000004	Ego 25/80-130	-	-	-	-	-	-	-	-	-
1576000005	Ego 25/40-180	25-4/180	25-4/180	25-4L	25-40/180	-	25-40/180	40-25/180	3m	NXL 33-25
1576000006	Ego 32/40-180	32-4/180	32-4/180	32-4L	32-40/180	-	-	40-32/180	-	-
1576000007	Ego 25/60-180	25-6/180	25-6/180	25-6L	25-60/180	25-60/180	25-60/180	60-25/180	5m	NXL 53-25
1576000008	Ego 32/60-180	32-6/180	32-6/180	32-6L	32-60/180	32-60/180	32-60/180	60-32/180	-	-
1576000009	Ego 25/80-180	-	-	25-7L	25/70-180	-	-	-	-	-
1576000010	Ego 32/80-180	-	-	32-7L	32/70-180	-	32-70/180	-	-	-

## THREADED/FLANGED CIRCULATORS COMPARISON WITH COMPETITORS

for medium/industrial plants

### COMPARISON WITH COMPETITORS - THREADED/FLANGED CIRCULATORS

EBARA		DAB		GRUNDFOS			WILO	
Code	Model	Electronics EVOPLUS	3 speed	Electronics Magna 1	Magna 3	3 speed UPS	Electronics	3 speed TOP S
1576000063	Ego easy 25-60	60/180 M	A 50/180 M	25-60	-	UPS 25-55 180	STRATOS 25/1-6	25/5
1576000064	Ego easy 32-60	60/180 XM	A 50/180 XM	32-60	-	UPS 32-55 180	STRATOS 30/1-6	30/5
1576000061	Ego easy 25-80	80/180 M	A 80/180 M	25-80	-	UPS 25-80 180	STRATOS 25/1-8 TOP-E 25/1-7	25/7
1576000062	Ego easy 32-80	80/180 XM	A 80/180 XM	32-80	-	UPS 32-80 180	STRATOS 30/1-8	30/7
1576000011	Ego easy 25-100	110/180 M	A 110/180 M	25-100	-	-	-	-
1576000012	Ego easy 32-100	110/180 XM	A 110/180 XM	32-100	-	-	STRATOS 30/1-10	30/1-10
1576000092	Ego easy 25-120	110/180 M	A 110/180 M	-	-	-	-	-
1576000093	Ego easy 32-120	110/180 XM	A 110/180 XM	-	-	-	STRATOS 30/1-10	30/1-10
1576000013	Ego easy 32-100 F	B 110/220.32 M	-	32-100 F	-	UPS 32-100 F	STRATOS 32/1-10	-
1576000014	Ego easy 40-100 F	B 110/250.40 M	B 110/250.40 M	-	-	-	STRATOS 40/1-10 TOP-E 40/1-10	40/10
1576000016	Ego easy 50-100 F	-	-	-	-	-	-	-
1576000015A	Ego slim 40-120	B 120/250.40 M	BPH 120/250.40 M	40-120 F	40-120 F	40-120 F	STRATOS 40/1-12 TOP-E 40/1-10	40/10
1576000017A	Ego slim 50-120	B 120/280.50 M	BPH 120/280.50 M	50-120 F	50-120 F	50-120 F	STRATOS 50/1-12 TOP-E 50/1-10	50/10
1576000018	Ego C 65	B 120/340.65 M	BPH 120/340.65 T	65-120 F	65-120 F	65-120 F	STRATOS 65/1-12 TOP-E 65/1-10	65/13
1576000019	Ego C 80	B 120/360.80 M	BPH 120/360.80 T	80-120 F	80-120 F	80-120 F	STRATOS 80/1-12 TOP-E 80/1-10	80/10
1576000020	Ego C 100	B 120/450.100 M	-	100-120 F	100-120 F	100-120 F	STRATOS 100/1-12	100/10
1576000100	Ego TC slim 40-120	D 120/250.40 M	DPH 120/250.40 M	D 40-120 F	D 40-120 F	D 40-120 F	STRATOS D 40/1-12 TOP-ED 40/1-10	D 40/10
1576000022A	Ego TC slim 50-120	D 120/280.50 M	DPH 120/280.50 M	D 50-120 F	D 50-120 F	D 50-120 F	STRATOS D 50/1-12 TOP-ED 50/1-10	D 50/10
1576000023	Ego TC 65	D 120/340.65 M	DPH 120/340.65 T	D 65-120 F	D 65-120 F	D 65-120 F	STRATOS D 65/1-12 TOP-ED 65/1-10	D 65/13
1576000024	Ego TC 80	D 120/360.80 M	DPH 120/360.80 T	D 80-120 F	D 80-120 F	D 80-120 F	STRATOS D 80/1-12 TOP-ED 80/1-10	D 80/10

EBARA		LOWARA		CALPEDA	
Code	Model	Electronics	Not Electronics	Electronics	Not Electronics
1576000063	Ego easy 25-60	ATC 25-40	TLC H 25-7L	NCE H 25/60-180	-
1576000064	Ego easy 32-60	ATC 32-40	TLC H 32-7L	NCE H 32/60-180	-
1576000061	Ego easy 25-80	ATC 25-60	TLC H 25-8L TLC H 25-10L	NCE H 25/80-180	-
1576000062	Ego easy 32-80	ATC 32-60	TLC H 32-8L	NCE H 32/80-180	NC3 32-80/180
1576000011	Ego easy 25-100	-	-	NCE H 25/100-180	-
1576000012	Ego easy 32-100	ATC 32-90	TLC H 32-10L	NCE H 32/100-180	NC3 32-85/180
1576000092	Ego easy 25-120	-	-	NCE H 25/120-180	-
1576000093	Ego easy 32-120	ATC 32-90	TLC H 32-10L	NCE H 32/120-180	NC3 32-120/180
1576000013	Ego easy 32-100 F	-	-	NCE H 32F - 100	-
1576000014	Ego easy 40-100 F	-	-	NCE H 40F - 100	-
1576000016	Ego easy 50-100 F	-	-	NCE H 50F - 100	-
1576000015A	Ego slim 40-120	AFC 40-80	FLC 40-10	NCE G 40F - 120	NC 40-120/250
1576000017A	Ego slim 50-120	AFC 50-80	FLC 50-13	NCE G 50F - 130	NC 50-120/280
1576000018	Ego C 65	-	FLC 65-12	NCE G 65F - 130	NC 65-120/340
1576000019	Ego C 80	-	FLC 80-8	NCE G 80F - 130	NC 80-120/360
1576000020	Ego C 100	-	-	NCE G 100F - 130	-
1576000021A	Ego TC slim 40-120	AFCG 40-80	-	NCED G 40F - 130	NCD 40-120/250
1576000022A	Ego TC slim 50-120	AFCG 50-80	-	NCED G 50F - 130	NCD 50-120/280
1576000023	Ego TC 65	-	FLCG 65-12	NCED G 80F - 130	NCD 80-120/360
1576000024	Ego TC 80	AFCG 80-90	-	NCED G 100F - 130	-

I contenuti della presente pubblicazione non devono essere considerati ingaranti. EBARA Pump Europe S.p.A. si riserva il diritto di apportare senza preavviso le modifiche che riterrà più opportune.